

X6.4



413 - 414 - 415 P6-DRIVE





McCORMICK X6.4, FULL ALL-ROUND VISIBILITY

The name McCormick stands worldwide for uncompromising quality and innovation. As part of its ongoing commitment to improve its product offering, the company has expanded the X6 tractor family with the new Stage V **X6.4** P6-Drive series, a range of heavy-duty utility tractors that offers a unique combination of performance, versatility and comfort.

Designed to deliver reliable power in a compact footprint, the **X6.4** is a multi-purpose tractor that is equally at home in medium-sized fields, on livestock farms or on the road. As a true all-rounder, the **X6.4** has the capacity to perform a wide variety of tasks both in the field and on the farm, including ploughing, harrowing, sowing, cultivating, harvesting and material handling.

The new design with its sleek, powerful lines highlights the tractor's versatility. The High Vision cab offers a generous glazed surface allowing for superb all-round visibility. The one-piece bonnet has been redesigned to enhance the operator's view to the front. The new bonnet tilts 90 degrees and the coolers located in front of the radiator open fully from a single latch to allow quick and easy

maintenance. The cab interior is spacious and offers a comfortable working environment with automotive-style fit and finish. The **X6.4** can be fitted with up to 14 full-LED work lights, eight of which on the cab roof, that provide full all-round visibility during night time work.

The new FPT NEF 45 4.5-litre four-cylinder engine with power ratings up to 155 hp deliver superior performance in terms of traction and fuel consumption. Equipped with the advanced Hi-eSCR2 after-treatment technology, the engine of the new **X6.4** series is environmentally friendly and complies with Stage V emissions requirements.

The P6-Drive PowerShift transmission is entirely designed and manufactured at Argo Tractors factory. The hydraulic system features a high-flow pump that provides 114 l/min, while the electronic management of the hydraulic functions ensures precise implement control. A DSM 12-inch touch screen display allows for fast and precise control of both tractor and ISObus-compatible implements, making for superior driving accuracy and unmatched productivity.

HIGHLIGHTS

Cab

- › High Vision cab with large glazed surface and FOPS-certified roof with panoramic hatch for ventilation
- › Iso-mounted cab and IFS suspended front axle for additional traction, ride comfort and safety
- › DSM 12-inch touch screen display with new functions
- › Tilt- and depth-adjustable steering column tilting with instrument panel
- › New all-in-one SmartPilot Plus controller
- › Manual or automatic climate control

Design

- › New bonnet design for improved forward visibility
- › Interior with automotive-like fit and finish
- › Up to 14 full LED lights for perfect visibility in any situation

Engine

- › New FPT NEF 45 Stage V engine with power ratings of 135, 145 and 155 hp

- › 90-degree tilting bonnet and radiator coolers opening out for fast and easy cleaning
- › New 220L fuel tank, the largest in its class
- › Engine brake for more efficient and safer braking

Transmission

- › P6-Drive transmission: 6 PowerShift speeds and 4 robotised ranges
- › Maximum speed 50 km/h
- › Smart APS: automatic selection of the right gear to suit load conditions
- › Stop & Action with De-clutch function integrated into the brake pedal for a smoother driving experience
- › Creeper: 40 FWD + 40 REV speeds, minimum advance speed 380 m/h

Axles

- › IFS suspended front axle for improved traction in the field and greater comfort and stability on the road
- › Electrohydraulic 4WD and differential lock engagement

- › Maximum rear tyre size: 650/60R38, for a maximum load capacity of 9500 kg

Hydraulic system

- › Closed-centre load-sensing (CCLS) hydraulic system with up to 114 l/min flow rate
- › Up to 7 mechanical or electronic remote valves
- › Front hitch with 2500 kg lift capacity
- › Electronically-controlled rear hitch with up to 7200 kg lift capacity
- › Four-speed PTO and ground speed PTO

On-board technology

- › DSM touch screen monitor with new functions for enhanced performance and customised comfort
- › ISOBus and Precision Steering Management systems for maximum working accuracy
- › Fleet & Remote Diagnostics Management for efficient fleet management



HYDRAULIC SYSTEM

Configurable and efficient
page 20

AGRICULTURE 4.0

More control - More productivity
page 24

CAB

Visibility - Comfort -
Instruments
page

ISOBUS

Efficient implement
control
page 29

ENGINE

More power - Less con-
sumption - Stage V
page 14



SUSPENDED AXLE

Traction - Comfort - Safety
page 18

TRANSMISSION

P6 Drive
page 10



HIGH VISION, A FIRST-CLASS CAB WITH PANORAMIC VISION

All-round visibility to keep everything under control

High Vision, the new fully glazed four-post cab of the X6 tractor, is designed to provide unobstructed view in all directions. The cab is fitted with up to 14 full LED lights, eight of which located on the roof, that fully illuminate the work area in low-light conditions. Inside the cab, a 12-inch tablet-like touch screen display allows the user to customise the tractor's operation to best suit their needs. All controls are servo-assisted and intuitively arranged according to anthropometric principles. The new SmartPilot all-in-one joystick controller gives the operator precise control of all key tractor functions.

More comfort means greater productivity

The cab of the X6.4 is equipped with a mechanical suspension which, combined with the suspended front axle, provides superior ride comfort. The cab interior is fully sound insulated and the driver seat with air suspension system can be swivelled and adjusted in various positions. The climate control system distributes air evenly throughout the cab for maximum operator comfort. Every feature inside the tractor's cab is designed to help the operator to concentrate on productivity.

McCormick On-Board Technology: better results with less effort

The 12-inch DSM touch screen monitor has been improved with new, intuitive functions that allow the user to customise the tractor's operation to their precise needs. This results in increased comfort and productivity. McCormick's innovative on-board technology simplifies work, making it more efficient and productive.





HIGHLIGHTS

- › High Vision cab with four-post design, full glazing and FOPS-certified roof for unequalled all-round visibility.
- › Fully opening roof hatch for natural ventilation.
- › Mechanical cab suspension for stability and comfort on all terrains.
- › Swivel seat with air suspension system and tilt adjustment. Hide-away buddy seat for easier access to the cab.
- › Tilt-and depth-adjustable steering column tilting with instrument panel.
- › Data Screen Manager: 12-inch touch screen display with new functions.
- › Multifunction armrest with ergonomically-designed controller and integrated controls
- › New SmartPilot Plus all-in-one joystick.
- › Automotive-style interior with dark-coloured soft-touch materials for better dirt resistance.
- › Climate control system with eight-vent layout for uniform air distribution within the cab.
- › Radio DAB+ with MP3 player, Bluetooth and integrated microphone.
- › Up to 14 latest-generation full-LED lights, eight of which located on the cab.

MAKE YOURSELF COMFORTABLE AND START YOUR DAY

The innovative High Vision cab has been designed to provide exceptional all-round visibility, making field work easier and enhancing loader performance. The new cab is a fully glazed four-post design that tapers to the top. The panoramic cab roof is FOPS certified to protect operator from falling objects and features an opening hatch for natural ventilation. The rear-hinged doors further improve visibility. The mechanically suspended cab and the independent front axle suspension system (IFS) ensure maximum stability and comfort on all terrains.

Access to the driving position is easy thanks to large, well-spaced steps and to a hide-away buddy seat. The interior is spacious and well sound insulated to offer operators a quiet and comfortable working environment. The depth- and tilt-adjustable steering column is designed to tilt with the instrument panel and the driver seat is equipped with air suspension system, swivel feature and electrical height adjustment. The interior is finished with dark-coloured, easy-clean, soft-touch materials.





ADJUSTABLE STEERING WHEEL

The steering column can be adjusted in tilt and depth through a button and a lever. The instrument panel tilts with the steering wheel.

MyUser

The MyUser menu allows all operating parameters of the X6.4 – including menus, settings and language – to be saved and associated with each user's profile for full customisation in multi-operator applications.

MyHMF

The intuitive MyHMF menu allows the operator to program headland operations by defining a sequence of automated steps. This can be done even when the tractor is stationary.

MyTractor

The MyTractor menu allows the user to save and recall the tractor's operating parameters, such as for example the MyHMF menu, without the need to reconfigure them.

MyLights

The X6.4 can be equipped with up to 14 latest-generation full-LED work lights. Up to eight lights can be fitted on the roof of the High Vision cab, four at the front and four at the rear. The MyLights menu allows the operator to manage two different light configurations via the DSM touch screen display, so as to have reliable lighting in any situation.



The 12-inch DSM touch screen monitor with its intuitive, tablet-like interface offers new functions that allow the user to configure and customize the tractor's operation. The new SmartPilot joystick provides control of all key tractor functions. All main controls are ergonomically integrated into the multifunction armrest.

Comfort is standard in the High Vision cab. Creature comforts comprise multiple in-cab storage compartments – including a glass holder, a refrigerated bottle holder, a mobile phone holder and a document holder; two USB ports for charging mobile devices; DAB+ radio with MP3 player, Bluetooth and microphone; inside rear-view mirror. The new climate control system with eight vents ensures a uniform distribution of air flow. Up to 14 latest-generation full-LED lights, eight of which located on the cab, make loader work easier and provide reliable illumination for night time operation.





P6-DRIVE TRANSMISSION: READY FOR ANY CHALLENGE

With the Smart APS Auto PowerShift you shift gears automatically.

During towing or transport operations, the Smart APS Auto PowerShift function ensures that you have always the right gear for the job in hand: when you step on the gas pedal, the transmission shifts automatically based on engine speed parameters and load. A smart solution that improves tractor performance, operator comfort and fuel economy.

Stop & Action for a smooth and safe ride.

The Stop & Action function allows the operator to control the clutch with just a light pressure on the brake pedal. This will result in a smooth driving experience, comparable to that of a CVT transmission. In addition, based on the tractor's towed load, a dedicated software decides when to disengage the clutch for added safety.

P6-Drive transmission: productive in the field, active on the road.

Efficient and versatile, the P6-Drive transmission offers six PowerShift speeds and four ranges providing a total of 16 gears within a speed range from 4 to 12 km/h. The PowerShift technology ensures that the transmission does not lose power between gear changes providing optimum performance in any conditions. In addition, a new automatic lubrication system further increases transmission efficiency. The P6-Drive transmission is controlled by the new intuitive SmartPilot Plus multifunction joystick.

HIGHLIGHTS

- › P6-Drive transmission: 6 PowerShift speeds 4 ranges.
- › Robotised range shifting.
- › Creeper: 40 FWD + 40 REV speeds, minimum advance speed 380 m/h.
- › Maximum speed 50 km/h at reduced engine rpm for improved fuel economy.
- › New SmartPilot Plus joystick for precise control of all transmission functions.
- › Eco Forty and Top Fifty for fuel economy and reduced noise.
- › Speed Matching: automatic powershift selection based on tractor speed.
- › Smart APS Auto PowerShift: automatic shifting through all powershifts and ranges.
- › De-clutch button for clutch-less gear shifting.
- › Stop & Action feature: integrates the De-clutch function into the brake pedal.
- › Power shuttle lever adjacent to the steering wheel with response modulation.

P6-DRIVE TRANSMISSION: NEXT-GENERATION PERFORMANCE

Entirely engineered and manufactured at Argo Tractors' facilities, the P6-Drive next-generation transmission is designed to boost the tractor's performance. The **X6.4** offers four ranges with six PowerShift steps in each range, a robotised range shifting and an electrohydraulic steering-column power shuttle providing 24 forward and 24 reverse speeds. In addition, a creep speed option provides 40 speeds forward and 40 in reverse. With the P6-Drive transmission, the **X6.4** offers a top speed of 50 km/h at reduced engine rpm for true fuel economy.

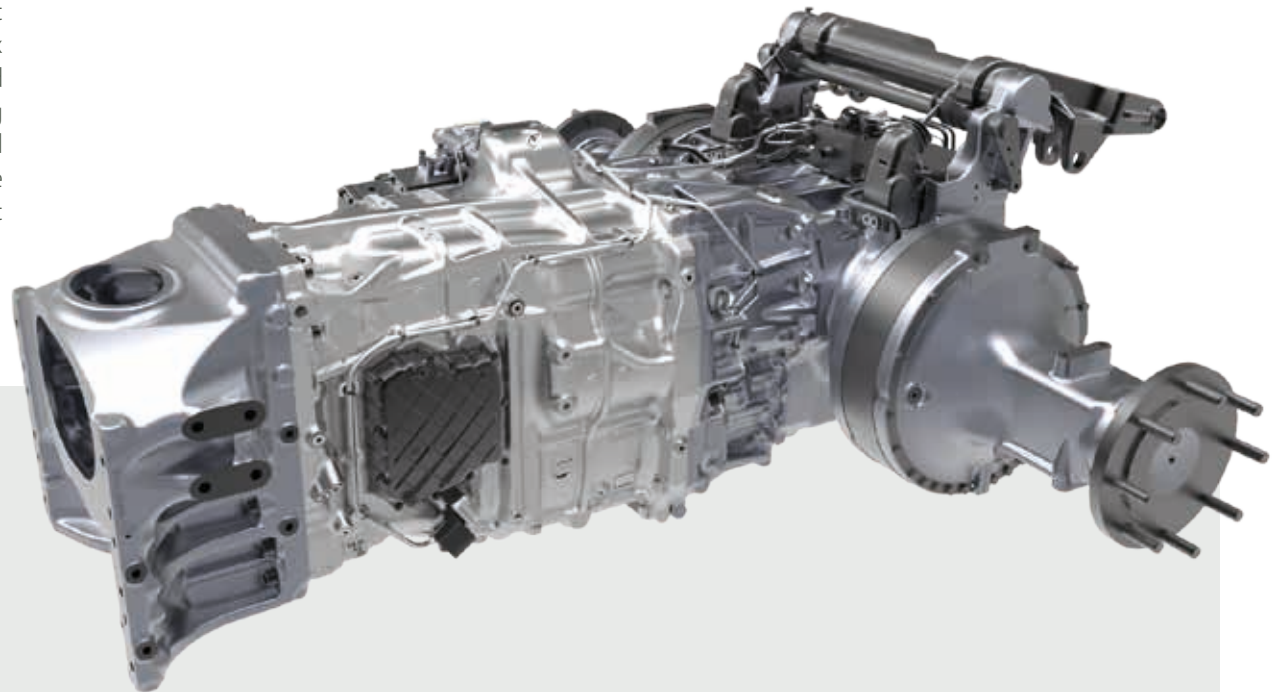

With the new SmartPilot Plus joystick you keep everything under control

Integrated into the multifunction armrest, the innovative SmartPilot Plus controller allows the operator to shift through all gears and ranges of the P6-Drive transmission without depressing the clutch pedal. The transmission engages immediately providing optimum traction both in the field and on the road. The SmartPilot Plus is an all-in-one joystick that gives the operator full intuitive control of key tractor functions: transmission, power shuttle, hydraulic system, rear hitch, front loader, PTO, automatic headland management and engine speed memories.

Smart APS Auto PowerShift automatic transmission

The Smart APS Auto PowerShift facility guarantees the best performance-to-fuel consumption ratio. The system automatically selects the right gear to suit load conditions, advance speed and engine rpm, making tractor driving easier, safer and more comfortable.

Stop & Action system

The Stop & Action system integrates the De-clutch function into the brake pedal, allowing the operator to stop the tractor without using the clutch pedal. By the combined use of the Stop & Action system and the APS facility, the P6-Drive transmission ensures a smooth driving performance, comparable to that of a CVT transmission.

Eco Forty and Top Fifty to reduce fuel consumption and noise

In the fast range, the Eco Forty mode enables the tractor to reach a speed of 40 km/h at 1572 rpm in order to reduce fuel consumption and noise levels during transport. The Top Fifty mode allows a top speed of 50 km/h at 1965 rpm for true fuel economy.



MULTIFUNCTION ARMREST

The controls of the P6-Drive transmission are integrated into the multifunction armrest of the driver's seat and allow the operator to control the following functions: headland management, PTO, four-wheel drive engagement, differential lock, engine rpm, rear hitch.

ELECTROHYDRAULIC POWER SHUTTLE

The steering-column power shuttle allows the operator to automatically shift from forward to reverse without using the clutch pedal. The shuttle response is electronically modulated and adjustable by the operator if required for different tasks. The power shuttle can also be conveniently operated with the SmartPilot Plus joystick.

RIGHT-HAND CONSOLE

The controls for the mechanical and electronic remote valves, the suspended front axle and the Precision Steering Management are built into the ergonomically-designed right-hand console.

SMART APS AUTO POWERSHIFT

The Auto Powershift (APS) will change the Powershift speeds based on engine speed parameters and load for up and downshifting. These parameters can be adjusted by the APS dial in the armrest from an ECO through to a Power setting.





NEW FPT NEF ENGINE: LESS CONSUMPTION, MORE EFFICIENCY



Fuel consumption is reduced by up to 10%.

Thanks to the innovative electronic common rail injection and Hi-eSCR2 after-treatment systems, the Stage V FPT NEF 45 engine reduces fuel consumption by up to 10 percent compared to equivalent tractor models.

High technology means high efficiency.

Designed to add value to your work, the new Stage V FPT NEF 45 engine will accomplish even the most challenging tasks with maximum efficiency in terms of power, torque and reliability.

Radiator cleaning is a five-minute job.

Reducing routine maintenance time improves work efficiency. To do this, McCormick has developed an innovative system that allows the coolers located in front of the radiator to open fully from a single latch to provide fast and easy cleaning in dusty conditions. This system reduces downtime and enhances engine performance.

HIGHLIGHTS

- › New FPT NEF 45 engine meeting Stage V emissions regulations.
- › Power Plus system to increase power up to 155 hp.
- › Turbo with intercooler and electronic common rail injection system.
- › Up to 44% torque backup.
- › Hi-eSCR2 emissions control system meeting Stage V emissions regulations.
- › Engine Brake function for enhanced braking efficiency.
- › New 220L fuel tank, the largest in its segment.
- › AdBlue® tank with 23L capacity.
- › Coolers open out from a single latch to allow easier and faster cleaning.

NEW FPT NEF 45 ENGINE FOR MAXIMUM EFFICIENCY IN THE FIELD



The three models of the **X6.4** series are powered by the new FPT NEF 45, 4.5-litre, 16-valve engines with power ratings of 135, 145 and 155 hp. The engine and transmission are arranged such that the wheelbase measures only 2560 mm, resulting in increased stability and better manoeuvrability. Designed with efficiency and reliability in mind, these engines are equipped with turbo, intercooler and electronic common rail injection system and meet the Stage V emissions regulations using the Hi-eSCR2 exhaust after-treatment system. The **X6.4** features a 220-litre fuel tank, the largest in its segment.

STAGE V COMPLIANCE ACHIEVED WITHOUT REDUCING VISIBILITY

The Hi-eSCR2 exhaust after-treatment system enables the **X6.4** tractors to fully comply with the Stage V emissions regulations. This technology integrates the SCR catalyst with a maintenance-free filtering device and guarantees a particulate-free combustion, thereby maximising engine performance while keeping emissions low. The Hi-eSCR2 system is tucked under the bonnet making for a clean, uncluttered design that provides unobstructed vision in all directions without compromising on the tractor's compact size.

MORE EFFICIENT BRAKING WITH THE ENGINE BRAKE

The engine brake ensures safer and more efficient braking thanks to a motorised throttle valve installed on the engine's exhaust pipe. A convenient foot pedal located in close proximity to the brake pedals activates the valve to increase the braking torque.

MORE BENEFITS WITH THE SHORT WHEELBASE

Boasting a wheelbase of only 2560 mm, the X6.4 offers more versatility, better manoeuvrability, and improved front traction and stability for both field and loader work.

The maximum torque is reached already at 1300 rpm. This allows a significant reduction in fuel and oil consumption and reduces engine wear considerably. The torque backup has been increased to 44 percent, further enhancing engine performance. The Power Plus system electronically adjusts the engine power to respond to varying load conditions. During transport applications or PTO operations, the Power Plus automatically delivers additional 10 hp, to handle tough conditions and heavy loads while maintaining speed and productivity. In addition, a new fuel injection strategy improves engine responsiveness and fuel economy.

COOLERS OPEN OUT FOR QUICK RADIATOR CLEANING

McCormick has developed an innovative system that allows the coolers located in front of the radiator to open out enabling easy, quick and thorough cleaning. The system increases cooling efficiency, thereby improving engine performance and fuel economy.





THE X6.4 IS STRONG AND LIGHTWEIGHT IN ANY SITUATION



The X6.4 is so easy to drive it makes every working day a breeze. With the X6.4 tractor, the drive is really easy and precise, since you don't need to continuously correct the steering. So, you can fully concentrate on the job at hand and will end your working day more relaxed.

The X6.4 is productive because it delivers traction, accuracy and comfort. The rugged front axle with independent suspension (IFS) of the X6.4 ensures excellent weight distribution and allows the tractor to transmit all the engine power to the ground with ease, resulting in enhanced traction and better manoeuvrability. This guarantees high levels of strength, accuracy, stability and comfort even on the toughest terrains.

Whether in the field or on the road, the X6.4 will surprise you with its versatility. The electrohydraulic engagement of the four-wheel drive and differential lock improves the pulling power both in the field and on the road, enabling the tractor to tackle all kinds of tasks and terrains with ease.

HIGHLIGHTS

- › IFS suspended front axle: traction, accuracy, stability and comfort on all terrains.
- › The X6.4 combines the tractive capacity of high-end tractors with the low soil compaction of mid-range tractors.
- › Electrohydraulic 4WD and differential lock engagement for improved traction performance.

IFS SUSPENDED FRONT AXLE: TRACTION, MANOEUVRABILITY AND COMFORT IN EVERY APPLICATION

The X6.4 can be equipped with either a rigid-mounted front axle or with an independent front axle suspension system (IFS) that allows each wheel to absorb impacts independently of one another. The rugged IFS suspended front axle combines outstanding traction with excellent manoeuvrability and comfort and transfers all the power to the ground making for better grip and stability both in the field and on the road. Equipped with Twin Lock differential locking system and electrohydraulic four-wheel drive engagement, the suspended front axle ensures safe operation on steep inclines and rough terrains and improves efficiency when operating a front loader or other front-mounted implements.

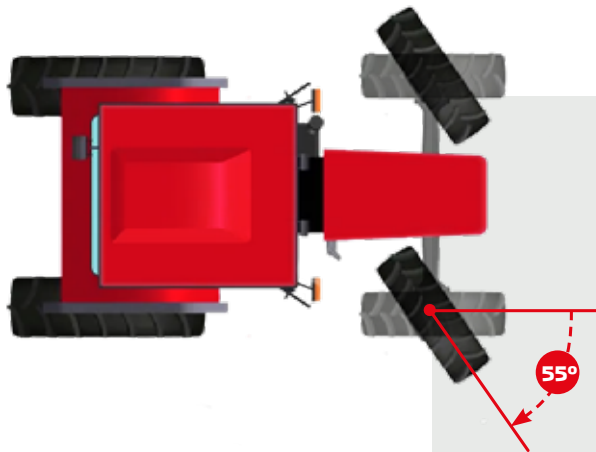

The X6.4 combines wide axle oscillation and high ground clearance with a 55-degree steering angle making for excellent manoeuvrability and driving accuracy in any situation. In addition, the hydrostatic power steering delivers smooth steering control even at low engine rpm. The suspended axle allows a top speed of 50 km/h.



HIGHLY **CONFIGURABLE** HYDRAULIC SYSTEM FOR MAXIMUM **PRODUCTIVITY**

The tractor's hydraulic system can be configured to your exact needs.

McCormick wants to be sure that the tractor is precisely tailored to the user's specific requirements. Built with high-quality components, the hydraulic system of the **X6.4** is highly configurable and features a primary pump that provides a flow rate of up to 114 l/min.

The CCLS hydraulics improve tractor efficiency and fuel economy

To optimise efficiency and ensure top-class performance, the **X6.4** is equipped with closed-centre load-sensing hydraulics. The CCLS hydraulic system is designed to deliver the required amount of oil to the remote valves only when demanded by the operator. This reduces fuel consumption significantly.

Powerful, easy-to-use front and rear hitch for precise implement operation

The **X6.4** features a new front hitch that can lift up to 2500 kg and an electronically-controlled rear hitch with a maximum lift capacity of 7200 kg. Both systems are controlled by the SmartPilot Plus, an ergonomic joystick that provides easy, intuitive and precise operation.





THE HYDRAULIC SYSTEM OF THE **X6.4** ENHANCES YOUR **PRODUCTIVITY**



The **X6.4** tractor range features a closed-centre load sensing hydraulic system (CCLS) with variable-displacement pump. This means that the pump always delivers exactly the quantity of oil that the system requires, thereby eliminating unnecessary power waste, reducing noise and fuel consumption and improving performance. The system supplies up to 114 l/min to the steering system, and to the hitch and remote valves, allowing for simultaneous operation of front and rear implements.

The PTO is designed to provide all the power necessary to operate heavy implements. The smooth, modulated engagement of the PTO ensures a soft start-up of the implement. The rear PTO of the **X6.4** offers four speeds: 540, 540Eco, 1000 and 1000Eco rpm. A ground speed PTO is also available to match the trailer's speed to the tractor's ground speed. When the PTO is operational, the Engine Power Management (EPM) system automatically adjusts the engine power to respond to varying load conditions, even when the tractor is stationary. The front hitch has a lift capacity of 2500 kg, while the rear hitch is capable of lifting up to 7200 kg.



McCORMICK M40 FRONT LOADER

Controlled by the precise, user-friendly SmartPilot Plus joystick, the sturdy M40 front loader provides smooth and reliable operation. The M40 front loader is the perfect match for your **X6.4** tractor, and together they provide superior comfort and productivity. The panoramic roof of the High Vision cab enhances efficiency during loader operation. All McCormick front loaders are compatible with the tractor's front hitch.

Configurable hydraulic system to suit your requirements

The **X6.4** tractor can be fitted with up to seven remote valves with push-pull quick couplings. The basic configuration includes three mechanically- or electronically-controlled rear remotes. Two electronic remote valves and a flow selector with a two-way flow divider are available as an option to operate two hydraulic functions with a single remote valve. The **X6.4** can also be equipped with two electronically-controlled mid-mount remotes. The electronic remote valves are controlled by the SmartPilot Plus multifunction joystick or via intuitive fingertip controls ergonomically integrated into the right-hand console.

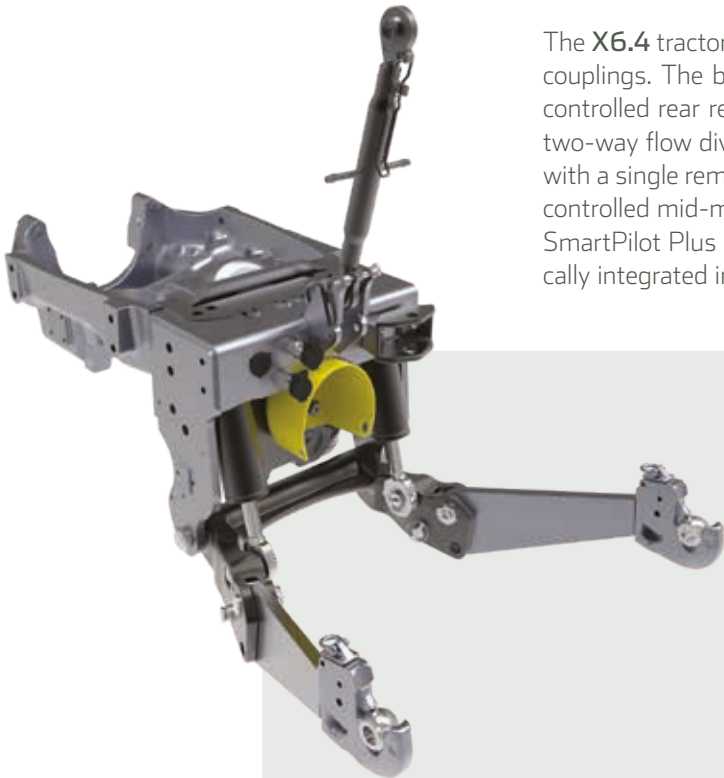

FRONT HITCH AND FRONT PTO FOR MAXIMUM VERSATILITY

The front hitch and the front PTO can be used in combination with the rear implements to add greater versatility to the **X6.4** tractor. The front hitch Category III features raise/lower and float controls and offers a maximum lift capacity of 2500 kg. The 1000-rpm PTO is engaged by a pushbutton. External PTO and hitch controls are located on the rear fenders making it easier to attach implements from the ground. The electronic rear hitch can lift up to 7200 kg.



FLOW SELECTOR FOR MULTIPLE HYDRAULIC FUNCTIONS

The flow selector features a flow divider with two quick couplings that operates two hydraulic functions with a single remote valve. This means the operator can control up to six hydraulic functions with five remotes and one flow selector.





AGRICULTURE 4.0: McCORMICK TECHNOLOGY FOR PRODUCTIVITY

McCormick's precision farming solutions cut your costs by 13 percent.

Comparative research in the agricultural sector has demonstrated that the satellite guidance system installed on the X6.4 delivers up to 13 percent total savings on costs of fuel, equipment, fertilisers and pesticides.

ISObus and ISObus Green increase your productivity.

The ISObus system improves efficiency and productivity by connecting the on-board computer to the tractor and implements without the need to install a control unit inside the cab. The intuitive touch screen display allows for immediate and precise control of each parameter. McCormick is also a leading participant in the innovative ISObus Green project, a solution that allows farmers to retrofit their existing implements to make them ISObus compatible – a real benefit that maximises farmers' productivity.

Satellite guidance and Fleet & Remote Diagnostics Management help you reap profits.

With the Agriculture 4.0, McCormick reduces costs and increases efficiency, thereby maximising your profits. The satellite-based guidance system gives you a degree of accuracy that even the most expert operators cannot achieve: a deviation of maximum 2 cm from the desired path. The Fleet & Remote Diagnostics Management system allows you to: A) Monitor your fleet: position, speed, consumption and other parameters; B) Analyse data: costs, efficiency and productivity; C) Perform remote diagnostics and maintenance: reduced downtime and improved performance; D) Store operating data: errors are eliminated and efficiency is increased.

McCORMICK PLAYS A KEY ROLE IN **AGRICOLTURA 4.0**

Technological innovation improves working conditions, increases productivity and supports the environment. Following this philosophy, McCormick has prepared its tractors for precision farming strategies and fleet management monitoring. These applications offer a number of benefits: the satellite guidance system provides unequalled steering accuracy; the ISObus system ensures efficient control of implement activities, including fully automated tasks; telemetry systems allow users to monitor fleet activity and analyse machine performance data; remote diagnostics allows machine issues to be remotely diagnosed. McCormick responds to customers' needs by offering more efficiency and profitability while improving simplicity, safety and comfort.



PRECISION STEERING MANAGEMENT FOR PRECISION PERFORMANCE



Precision farming as a concept has been in existence ever since man started to cultivate land. Today, thanks to technological development, precision farming is carried out with innovative tools that improve efficiency and increase productivity. McCormick uses the innovative PSM (Precision Steering Management) system, a set of integrated devices for satellite-assisted guidance that can be managed from the tractor cab via a simple touch screen display. The precise steering control – obtained through an electronic hydrostatic power steering system and through steering sensors – delivers pass-to-pass-accuracy levels down to 2 cm. This high degree of precision reduces operating costs and time, lowers environmental impact and increases efficiency and productivity.

ISOBUS & ISOBUS GREEN MAKE YOUR WORK SIMPLE AND EFFICIENT

In 2015, Argo Tractors received the AEF Isobus certification. The ISObus system is the standard protocol through which the on-board computer communicates with the tractor and implements. All ISObus-compatible implements are managed via a DSM 12" touch screen monitor to improve operating efficiency and productivity.

McCormick is a leading participant in the innovative ISObus Green project. This solution enables farmers to retrofit their mechanical implements with the technology so as to connect them to the tractor's ISObus system. With the ISObus Green project farmers will maximise the productivity of their implements.





McCORMICK FLEET MANAGEMENT HELPS FARMERS GROW PROFITS

As a company traditionally committed to technological innovation, McCormick equips all its tractors with remote management and diagnostic capability. The McCormick Fleet & Diagnostics Management system helps farmers to make data-driven decisions; this reduces operating costs while increasing efficiency and productivity. This advanced solution is based upon four key elements:

1. Real-time fleet monitoring: the system displays the exact location of each tractor in a fleet and monitors its efficiency by checking parameters like speed, engine performance, average consumption and work progress.

2. Data analysis: the system calculates the cost, efficiency and productivity of each tractor and determines the farm's profit margin. These data are essential to make forecasts and organise work plans.

3. Remote diagnostics and maintenance: our after-sales service responds and intervenes in real time in order to adopt the best solutions and to improve tractor performance. This reduces downtime and extends equipment life.

4. Storage of working data: the system outlines the work areas and saves the activity data for further use. This eliminates errors and maximises efficiency.

Designed to effectively respond to customers' needs, the McCormick Fleet Management helps farmers make the most appropriate choices in order to maintain their tractors in good working order, optimise their work and increase their business profitability.

Precision Steering Management & ISObus bring benefits to the field

The Precision Steering Management and the ISObus system are some of the technologies adopted by McCormick to increase efficiency and productivity while improving comfort and safety:

- > All implement activities, including fully automated tasks, are managed with a high level of precision.
- > When the user must drive the tractor and simultaneously operate the implement, the satellite guidance system (Precision Steering Management – PSM) allows full concentration on the task at hand.
- > The satellite-based guidance system tracks planned work paths precisely, making

tractor driving more accurate and comfortable.

- > Reducing the travelled distance in the field reduces tractor and implement wear and tear while saving fuel.
- > The use of variable rate application eliminates skips and overlaps, minimizing product waste. Variable rate technology reduces overuse of water, seed use by 10%, fertiliser use by 16% and herbicide use by up to 60%.
- > Chemical residues are also reduced with significant benefits for the environment.
- > Report and pre-setting operations are simpler and can be conveniently done from home. This eliminates the need for expert operators.

QUICK MAINTENANCE TO GET YOU UP AND RUNNING IN NO TIME



Designed to deliver maximum efficiency and reliability, the **X6.4** range offers a variety of solutions to simplify and expedite maintenance.

1. The tilt-up bonnet opens 90° to provide easy access to the engine compartment for maintenance and radiator cleaning.
2. The oil filler cap is placed in the lower part of the engine, so topping up of engine oil can be done without opening the bonnet.
3. The engine air filter is conveniently placed to facilitate cleaning and replacement.
4. The cooling radiators open fully from a single latch to allow fast and easy cleaning.
5. The fuel and AdBlue tanks are conveniently placed to allow quick filling. Tank caps have different colours to avoid mix-up.
6. The in-cab air filter is easily accessible for maintenance.
7. The oil level in the transmission can be conveniently checked through the oil filler cap with level gauge placed on the rear of tractor.





MCCORMICK



McCORMICK ORIGINAL SPARE PARTS, THE CORNERSTONE OF YOUR PRODUCTIVITY

Although it works hard, your McCormick tractor always looks good as new. With McCormick original parts time seems to have stopped. Our original spare parts are an integral part of our scheduled maintenance and extended warranty program. Developed by the same engineers who design and manufacture the McCormick tractors, genuine McCormick parts are designed and manufactured to the highest quality standards to ensure reliable and safe performance over time.

The strong points of McCormick original spare parts are:

- **Speed:** Spare parts are always shipped within 24 hours of order receipt.
- **Quality:** Each part comes with a 12-month warranty and is marked with a tamper-proof hologram that certifies the product's quality and originality.
- **Convenience:** Original McCormick parts are reliable and convenient: they improve your tractor performance, maintain high productivity levels and preserve your tractor's value.

All McCormick spare parts rely on our extensive design and manufacturing expertise. Because when you choose McCormick, you are choosing quality without compromise.







POWER TECHNOLOGY SINCE 1847

Cyrus Hall McCormick was born in Virginia, United States, in 1809. A keen inventor, he stunned the agricultural world with inventions that mechanised the farm work. In 1831 he invented the first mechanical reaper. In 1847 McCormick established a factory for the production of grain harvesters. In 1866 the company adopted the red colour that still identifies the brand worldwide. In 1871 McCormick manufactured more machines than any other company in the world: 250 reapers per day. The first tractor, the Mogul 8-16, was launched in 1906. In those years, the company opened up factories in Canada, Great Britain, Germany, France and Sweden.

In the following years, the company was purchased and sold several times. In 2000 McCormick was acquired by the Argo Group, which relaunched the brand under the name McCormick Tractors International Limited. Today, McCormick is a world leader in the tractor industry and its name stands for uncompromising technology and innovative design. Thanks to heavy investments in research and development, the new generation of McCormick tractors leads the market for performance and innovation. Farmers look for efficient, reliable and versatile solutions to maximise their productivity – and this is exactly what we are proud to offer our customers.

		X6.413 P6-DRIVE	X6.414 P6-DRIVE	X6.415 P6-DRIVE
ENGINE				
Max power (97/68/EC - ISO/TR 14396)	hp / kW	125.1/92.0	135.3/99.5	144.1/106.0
Max power with EPM (97/68/EC - ISO/TR 14396)	hp / kW	135.3/99.5	145.6/107.1	154.9/113.9
Engine speed at max power	rpm		1800	
Max torque without EPM (with EPM) at 1400 rpm	Nm	520 (551)	551 (610)	600 (630)
Manufacturer			FPT	
Engine type			NEF 45	
Stage V / Tier 4 Final exhaust after-treatment system			HI-eSCR2	
Cylinders/ Displacement / Valves			4 / 4.5 l / 16	
Air intake system			turbo intercooler	
Maintainance			500 hours maintenance interval	
CAPACITIES				
Fuel tank	l		220	
AdBlue / DEF tank	l		23	
TRANSMISSION				
Type			<ul style="list-style-type: none"> • P6-Drive - 6 powershift and 4 synchronised ranges controlled by lever 	
No. of gears			<ul style="list-style-type: none"> • 36 FWD + 36 REV with creeper - o 24 FWD + 24 REV without creeper 	
Minimum speed	m/h - giri/min		0.36 with creeper - 2.4 without creeper (600/65R38)	
Engine speed at 40 km/h	giri/min		<ul style="list-style-type: none"> • - 1739 	
Engine speed at 50 km/h	giri/min		o - 1859	
Transmission & other controls			<ul style="list-style-type: none"> • - SmartPilot with multifunction armrest for control of powershift, RPS, engine memo switch, MyHMF, rear PTO, rear hitch 	
REAR PTO				
Speeds			<ul style="list-style-type: none"> • 540 / 540 E - o 540 / 1000 o 540 / 540 E / 1000 / 1000 E 	
FRONT AND REAR AXLES				
Front suspended axle			o - IFS - independent front wheel suspension system with brakes	
BRAKING SYSTEM				
Front braking system			oil-bath disc brakes	
Trailer braking system			pneumatic brake system with 2 or 2+1 lines with or without single-line hydraulic as per MR, 2-line hydraulic brake as per MR (with 40 km/h transmission only)	
Engine brake			o	
HYDRAULIC SYSTEM				
Hydraulic piston pump with CCLS system - flow rate			<ul style="list-style-type: none"> • - 123 l/min 	
Rear remote valves - number, type, flow rate			<ul style="list-style-type: none"> • - 3 mechanical remote valves with flow divider - 80 l/min - o - 3M + 2E, 5E - 100 l/min 	
Flow divider with flow selector - section flow rate			o - 2 sections - 100 l/min not continuously for each section - 60l/min continuously	
Mid-mounted remote valves - number, type, flow rate			2 electrohydraulic with multifunction joystick - 100 l/min	
REAR 3-POINT HITCH				
Electronically-controlled rear hitch			with lower link draft control, position control, mixed control, float position	
Category - coupler type			<ul style="list-style-type: none"> • II - quick-hitch hooks - o III - quick-hitch hooks 	
Max lift capacity at hitch points - ram diameter	kg		<ul style="list-style-type: none"> • 7200 (6600) - 90 mm 	

FRONT 3-POINT HITCH		
Electronically-controlled rear hitch		• - with position control
Category - coupler type		• III N - quick-hitch hooks
Max lift capacity at hitch points	kg	3200 (2500)
FRONT PTO		
Type		o - electrohydraulic multidisc clutch with modulated engagement
Speeds	rpm	1000
CAB		
McCormick mechanical cab suspension		o
DSM Data Screen Manager		o (with electrohydraulic remote valves) - 12" touch screen monitor
MyLights		• - with DSM
Work lights		o 14 - 2 on bonnet, 2 on handles (LED), 4 on roof front, 4 on roof rear, 2 on rear fenders (LED)
Full LED work lights		o 14 - 2 on bonnet, 2 on handles, 4 on roof front, 4 on roof rear, 2 on rear fenders
Beacon lights		• - left side o - left and right side
MISCELLANEOUS		
PSM Precision Steering Management, rear ISObus & EazySteer - ready		o
PSM Precision Steering Management, rear ISObus & EazySteer - EGNOS full kit		o
PSM Precision Steering Management, rear ISObus & EazySteer - RTK NTRIP full kit		o
McCormick Fleet Management - ready		•
McCormick Fleet Management - 3-year full plan subscription		o
WEIGHT AND DIMENSIONS		
Wheelbase	mm	2560
Shipping weight - measured with average specs	kg	5400
Gross vehicle weight	kg	9500
Max front and rear tyre sizes - (Index Radius - IR)	mm	520/60R28 VF (IR 650) - 650/60R38 VF (IR 825)

Key: • standard o option



Power Technology.

via G. Matteotti, 7 | 42042 Fabbrico [RE] Italia | t. +39.0522.656.111 | f. +39.0522.656.476
webmaster@argotracors.com | www.argotracors.com



progetto grafico: **gruppo saldatori** | bzzbz@grupposaldatori.com
I dati tecnici del seguente depliant sono forniti a puro titolo
informativo e possono essere modificati senza preavviso



6725797A1