

X6



35 - 45 - 55





McCORMICK X6, THE ALL-ROUND SPECIALIST

McCormick has contributed to writing the history of agricultural mechanization. A history that continues today with Argo Tractors, an international group of companies that makes technology innovation and quality the focus of its daily activities. This ongoing commitment has led Argo Tractors engineers to develop a truly innovative range of high-performance utility tractors that has no equal for versatility, simplicity, reliability and comfort.

The McCormick **X6** sets a new milestone in compact tractors for field work. Designed with versatility in mind, the **X6** tractor will handle a variety of tasks, from field operations such as soil preparation, sowing and haymaking to barn management activities, with ease and in complete safety. Engineered and built to carry out all daily tasks in the farm with total reliability and maximum comfort, the **X6** tractor is the perfect choice for medium-scale stand-alone farms that tend to be cautious when it comes to make new investments in their vehicle fleet.

The **X6** tractor is highly versatile and completely customizable to meet farmers' specific needs. Tractor key features include:

- A four-post cab with ergonomically-positioned controls for maximum ease of operation and a transparent roof hatch providing extra visibility for front loader operations. The low-profile roof allows easier access to low-ceiling barns and sheds.

The **X6** tractor can be optionally equipped with a satellite-based guidance system and an ISOBUS terminal to maximize productivity and profitability.

- New Deutz AG 3.6L engines with power ratings of up to 126 hp. These engines meet the Stage4/Tier4 Final emissions regulations using a selective catalytic reduction system (SCR) and a diesel oxidation catalyst (DOC).
- The transmission incorporates standard a power shuttle and can be integrated with an Xtrashift three-stage powershift (high, medium, low) and a creeper providing 48 forward and 16 reverse speeds.
- A choice of three front axles: two rigid-mounted (wide or narrow), and one with independent suspensions. As an option, the tractor can be fitted with 38-inch rear tyres.
- The four-wheel drive, the differential lock and the PTO, with either two or four speeds, are electro-hydraulically engaged.
- The open-centre hydraulic system ensures optimum operation of the rear hitch and of up to six remote valves.
- Optionally, the **X6** can be fitted with a front hitch and PTO system and an M Series front loader.

The name McCormick has always stood for innovation. Choosing McCormick means you can count on a reliable partner that gives you state-of-the-art technology and unmatched versatility without compromising on simplicity.

HIGHLIGHTS

Cab

- › Deluxe Slim cab: unequalled all-round visibility, ergonomic controls and high-quality fit and finish
- › Driver's seat with air suspension system
- › Low-profile cab roof for easy access to low-ceiling barns and sheds
- › Mechanical cab suspension for superior comfort
- › 8.4-inch touch screen monitor for satellite guidance and ISOBUS control

Engine

- › Deutz AG 3.6L engine delivering up to 126 hp
- › Exhaust gas after-treatment with SCR/DOC system and AdBlue® tank to meet Tier 4 Final emissions regulations

Transmission

- › Xtrashift transmission with three-stage powershift (H-M-L)

Axles

- › Wide or narrow rigid-mounted front axle for different tractor widths
- › Front axle with central suspension system and integrated brakes available as an option

Hydraulic system

- › Open-centre hydraulic system with 66 l/min flow rate. Additional 11-litre hydraulic oil tank available as an option
- › Rear hitch with up to 6000 kg lift capacity
- › Rear 4-speed PTO



EXHAUST SYSTEM

Emissions under control
page 14

SATELLITE-BASED GUIDANCE

Higher accuracy, greater productivity
page 32

CAB

Perfect visibility
and first-class comfort
page 6

HYDRAULIC SYSTEM

Innovative, for maximum
configuration flexibility
page 22

ISOBUS

Simple and efficient
implement control
page 33

ENGINE

A new heart
page 13



ELECTRONIC HITCH

Powerful and easy to use
page 24

SUSPENDED AXLE

Unmatched manoeuvrability
page 20

TRANSMISSION

Versatile and tailored to suit every need
page 14





DELUXE SLIM CAB, DESIGNED FOR SIMPLICITY



Just easy: when simplicity is at the heart of design

Inside the Deluxe Slim cab, simplicity is wanted, searched for and designed. Built-in simplicity has a concrete purpose: to make those long working days in the field less tiring and stressful. Not only the cab, but also the whole tractor has been designed and built with simplicity and efficiency in mind. You don't need to be an engineer to use this tractor, because the McCormick **X6** is just easy.

You are inside the cab but it looks like you are outside

The Deluxe Slim cab offers a spacious, fully-glazed working environment and a transparent roof hatch that give the operator perfect all-round visibility, making front loader operations and manoeuvres in tight spaces, where unobstructed view at close range is paramount, easier and safer.

Functional and user-friendly, the Deluxe Slim cab has all you need

Equipped with all you need to work efficiently, the Deluxe Slim cab turns simplicity into efficiency. Perfectly sound-insulated, the cab interior features an automotive-style fit and finish with soft-touch materials and a highly-efficient automatic climate control that maintains an ideal cab temperature whatever the outdoor weather conditions. The driving position is equipped with a telescopic, tilt-adjustable steering wheel, a Bluetooth radio and a hands-free phone.

NEW DELUXE SLIM CAB: ALL-ROUND VISIBILITY AND TOTAL COMFORT



Specially designed for the X6 tractor range, the new Deluxe Slim cab helps reduce operator stress and fatigue during long working days. Spacious and perfectly soundproofed, the cab interior features an automotive-grade fit and finish with soft-touch, easy-clean materials.

And that's not all: a highly efficient heating, ventilation and air conditioning system, conveniently built into the low-profile cab roof, maintains a comfort-

able working environment whatever the outdoor weather conditions. The rear windscreen and the roof hatch can be opened to provide natural ventilation. The mechanical cab suspension system further enhances ride comfort.

With its superb all-round visibility, the Deluxe Slim cab makes front loader operations and manoeuvring in tight spaces and at headlands, where short-range visibility is critical, easier and safer.

DRIVER SEAT AND HIDE-AWAY BUDDY SEAT

Large and comfortable, the driver seat is available with either a mechanical or air suspension system that can be adjusted to suit the driver's weight. Passengers can also travel in comfort thanks to an upholstered buddy seat, which neatly folds away to allow easier access to the cab.

ACCESS TO DRIVING POSITION

Fully glazed rear-hinged doors provide easy access to the driving position. Wide, sturdy access steps and handrails fitted to the cab posts and to the doors allow operators to safely climb up and down the tractor.



HIGHLIGHTS

- › McCormick's latest design with aggressive, contemporary looks
- › Telescopic steering wheel tilting with instrument panel
- › Highly-efficient climate control thanks to the air-conditioning system integrated into the cab roof
- › Opening transparent roof hatch for extra visibility during front loader operations
- › Six work lights for proper illumination during night work



MECHANICAL CAB SUSPENSION

The new mechanical cab suspension system isolates the tractor body from wheel vibrations induced by uneven ground conditions, ensuring maximum ride comfort and safety on all terrains.

AIR CONDITIONING AND OPENING ROOF HATCH

The heating, ventilation and air conditioning system, integrated into the cab roof, maintains a comfortable working environment whatever the outdoor weather conditions. The rear windscreen and the roof hatch can be opened to allow natural ventilation.



BLUETOOTH RADIO

The Bluetooth AM/FM radio allows listening to music also through an MP3 player, an AUX cable or a USB flash drive, while an integrated microphone allows the driver to make hands-free phone calls.



INSTRUMENT PANEL AND STEERING WHEEL

The steering wheel is telescopic and tilt adjustable. The instrument panel, which tilts with the steering column, features easy-to-read digital and analog gauges and instruments for easy monitoring of tractor functions.

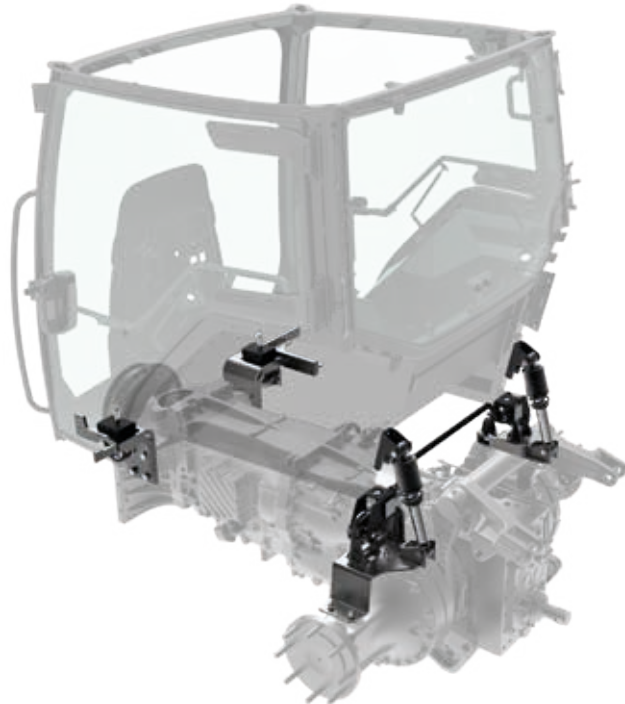



MINIMUM CONSUMPTION FOR MAXIMUM EFFICIENCY

Compare consumptions: the X6 is fuel economy champion in its class

The McCormick **X6** has ultra low fuel consumption for the power developed. This is due to the absence of an exhaust gas regeneration process and to the presence of the Engine Memo Switch, a device that allows operator to store and recall the engine speed most suited to the implement used.

Time saving: maintenance has never been so quick

You just need to open the hood of the **X6**: the most often used components are within easy reach and simple to maintain. Also, service intervals are longer and maintenance operations faster, as the main service activities require a little time and can be performed without disassembling any parts.

Maximum safety when working in closed environments

The post-combustion process, achieved through the injection of additional fuel, breaks up the particulate matter retained in the diesel particulate filter (DPF), thereby reducing its harmful effects on human beings and the environment. However, as the DPF is connected to the exhaust muffler, during post-combustion some sparks of incandescent particulate matter might be ejected and fall onto dried powders, forage or straw causing damage or hazard to people. The McCormick **X6** is equipped with DOC/SCR system and has eliminated the need for a DPF, making daily barn activities totally safe.



DEUTZ AG ENGINE: YOUR TRUSTED WORKMATE

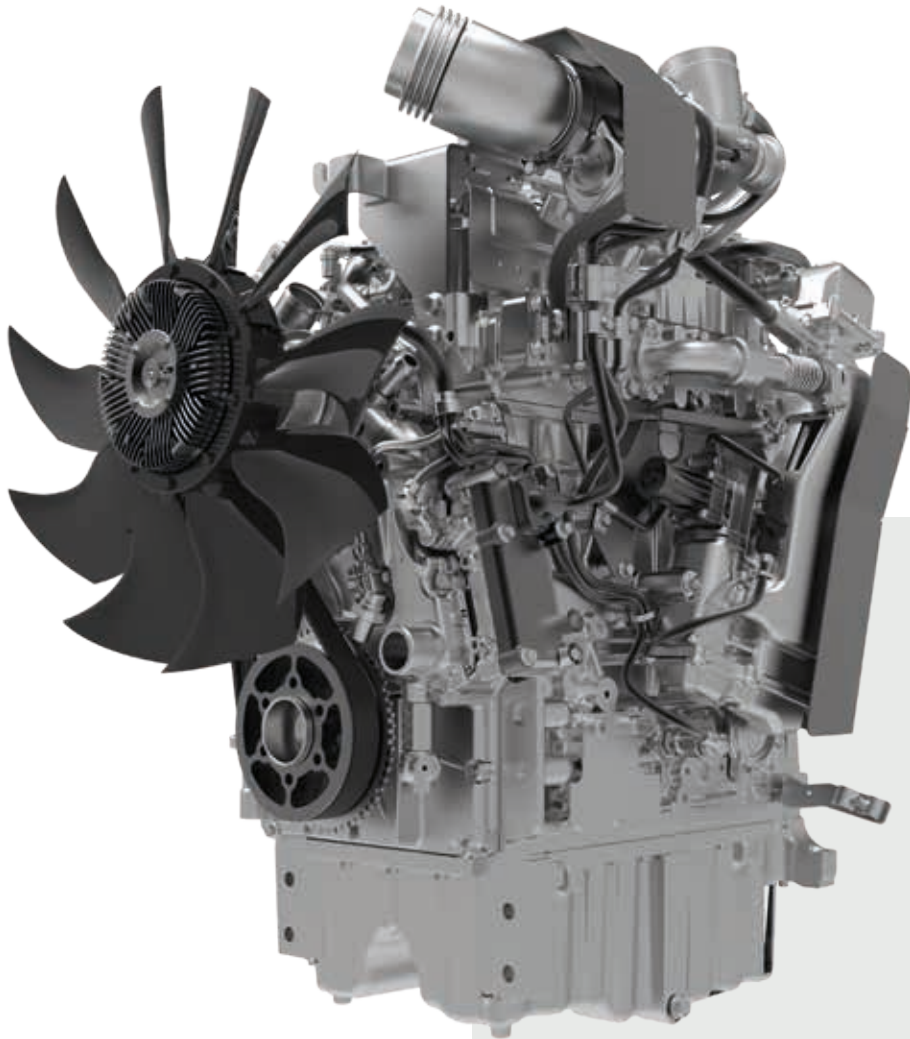

The three models of the **X6** Series are powered by advanced Deutz AG 3.6L four-cylinder turbo engines with multivalve technology, intercooler and common rail injection system. These innovative engines meet the Stage 4/Tier 4 Final emissions regulations using a selective catalytic reduction system (SCR) combined with a diesel oxidation catalyst (DOC).

Fuel economy

The Deutz AG engines that power the **X6** series are equipped with common rail, a computerized fuel injection system that provides a precisely measured amount of fuel to the engine, thereby reducing consumption while maximizing performance. Fuel efficiency is further enhanced with the Engine Memo Switch, a device that allows the operator to store and recall the engine speed most suited to the implement used. The **X6** tractor is equipped with a 150-litre fuel tank for extended operation without refuelling.

SCR/DOC system to cut down on exhaust emissions

The SCR technology, or Selective Catalytic Reduction, utilizes Adblue® fluid to reduce engine exhaust emissions. The fluid is injected from a dedicated tank into the exhaust system and then conveyed to the SCR system where it reacts with exhaust gases, thereby reducing significantly the NOx emissions. The SCR system, used in conjunction with a DOC catalytic converter – a passive diesel oxidation catalyst that reduces primary pollutants – ensures compliance with the Stage 4/Tier 4 Final emissions regulations.

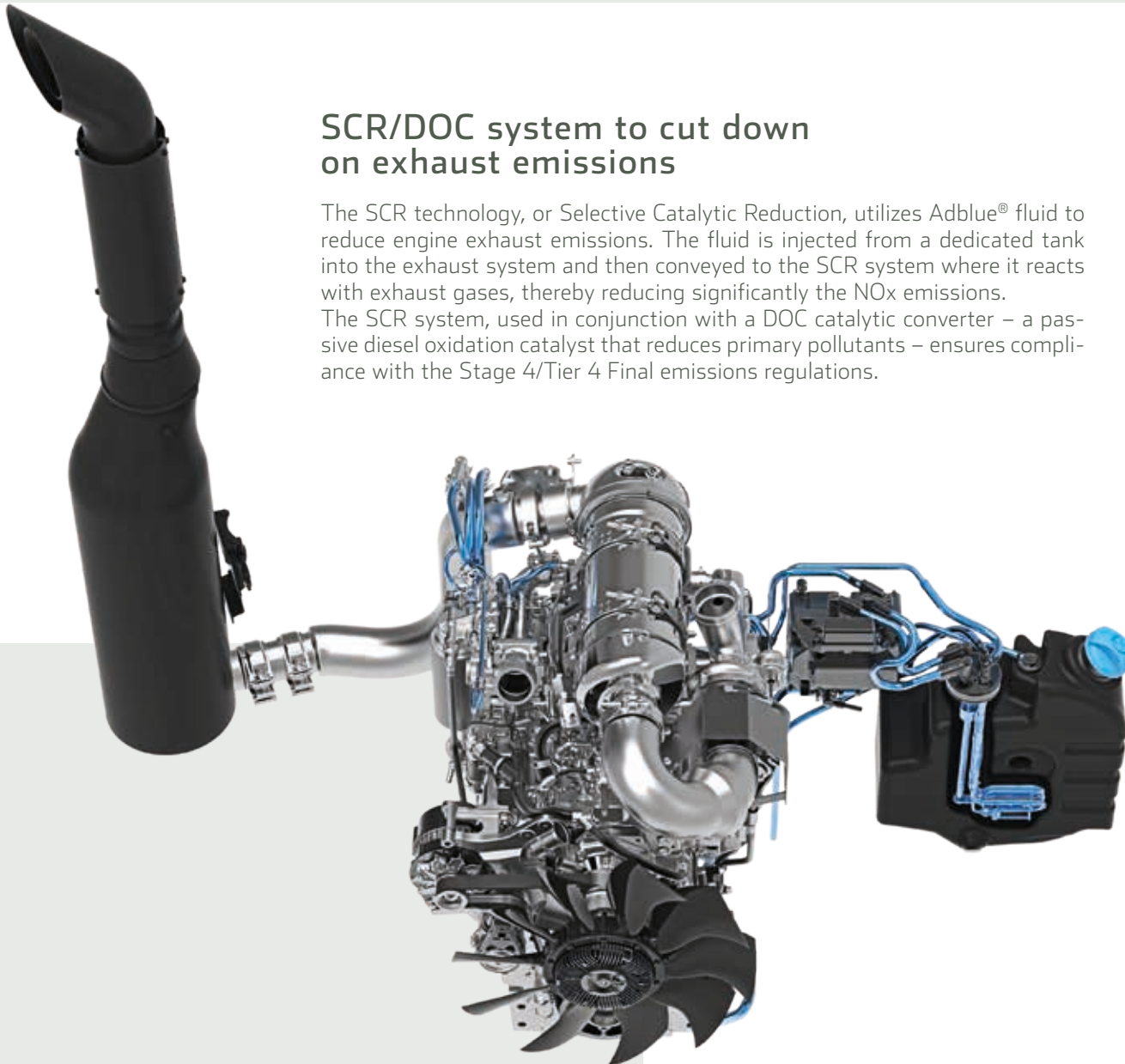

McCORMICK X6	POWER HP	POWER KW	MAX TORQUE
X6.35	110	81	440
X6.45	119	88	476
X6.55	126	93	500

ADBLUE® TANK

The AdBlue® tank holds 20 litres of fluid for the SCR system which represents the best solution to the Stage 4 / Tier 4 Final emission standards







A RUGGED TRANSMISSION THAT NEVER LETS YOU DOWN

The X6 always works at full strength

The X6 is by any standards a truly versatile tractor that allows choosing among several transmission configurations to address each farm's specific needs. Whatever the choice, all McCormick transmissions have one common feature: they are derived from higher-category machines and are therefore designed to provide top-notch durability along with uncompromised performance and total reliability under all operating conditions.

Never more power losses!

When travelling either on the road, on mixed terrain or on sloping ground, the transmission of the X6 will allow you to maintain a constant power under varying load conditions, while keeping tractor performance unaltered.

High-efficiency transmissions

From mechanical to latest-generation automatic powershift transmissions, all McCormick transmissions are designed to deliver maximum efficiency and ultimate operator comfort. Based on this design philosophy, these transmissions are built to enhance the specific features of the tractor, thereby ensuring excellent performance in any conditions.



TRANSMISSION CONFIGURABLE TO YOUR SPECIFIC NEEDS



Designed with versatility in mind, the **X6** tractor range offers a variety of transmission configurations to respond more effectively to the specific needs of each farm. Options available range from a basic 12/12 Speed Four transmission with power shuttle up to an electrohydraulic 48/16 Xtrashift transmission with HML powershift and creeper.

Speed four transmission

The Speed Four transmission with left-hand steering-column power shuttle offers four synchronized speeds and three ranges providing 12 forward and 12 reverse gears. A creep speed option offers 16 forward and 16 reverse gears with speeds as low as 310 m/h.

Xtrashift electrohydraulic transmission

The Xtrashift transmission triples the 12 gears of the Speed Four transmission providing 36 forward and 12 reverse speeds for maximum efficiency in the field and on the road. An optional creeper provides up to 48 forward and 16 reverse gears and allows speeds as low as 310 m/h. The de-clutch button and the power shuttle allow the operator to shift through all gears and change from forward to reverse without using the clutch pedal. The shuttle response is electronically modulated and adjustable by the operator if required for different tasks.

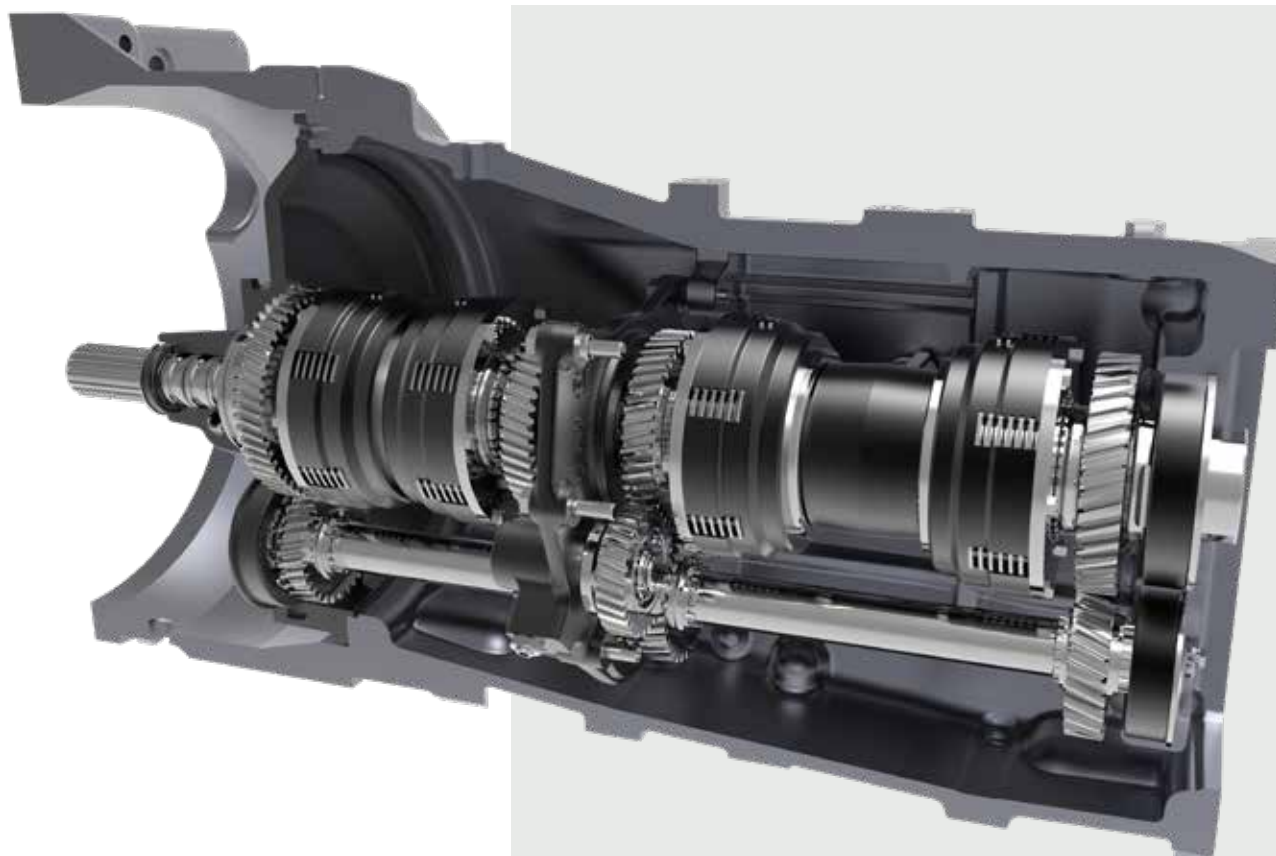

PARK LOCK, SAFETY GUARANTEED

The power shuttle transmission can be optionally equipped with Park Lock, a mechanical locking device which locks the transmission for added safety when parking the tractor on steep inclines.

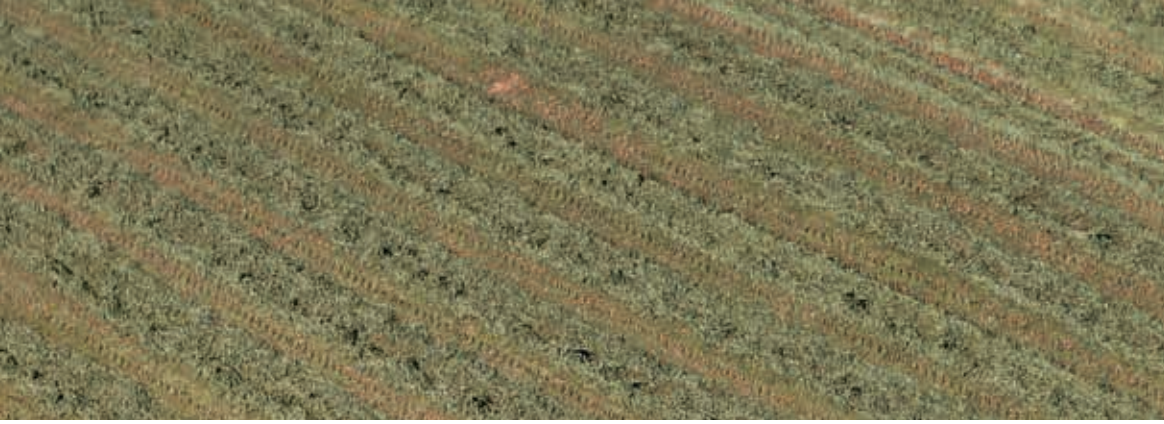

McCORMICK X6, BUILT TO WORK WITH LIGHTNESS



McCormick X6, for those who want less soil compaction

During field work, the **X6** ensures reduced soil compaction through proper weight distribution, 45% in the front and 55% to the rear. This optimum weight distribution between the two axles makes the **X6** the best balanced tractor in its power class.

With the X6 tractor driving is simple and precise

The **X6** allows a precise and simple driving and does not require continuous correction of the vehicle direction. Thus, the operator can better concentrate on the job in hand and will feel less tired after a full working day.

Spring-on system for maximum active safety

The Spring-on system is designed to provide powerful, efficient four-wheel drive in any situation, thereby preventing slippage and allowing greater concentration on the task in hand.



McCormick X6 for optimum stability in any situation

The **X6** Series offers outstanding traction and manoeuvrability ensuring optimum grip and stability for superior driving comfort on all terrains. The rugged front axle, either rigid-mounted or with independent suspensions, is equipped with Twin Lock full locking differential and electro-hydraulic four-wheel drive engagement. This ensures maximum efficiency and safety in any condition, including when working with a front hitch or a front loader. The rear axle, derived from higher class vehicles, is sturdy and reliable. With its large front axle swing, its excellent ground clearance and a steering angle of 55 degrees, the **X6** tractor is highly manoeuvrable in any situation, while the hydrostatic drive delivers smooth steering control even at low engine rpm.



Front axle with hydraulic central suspension system

A front axle with electronically-controlled dual-cylinder central suspension system is available as an option. Featuring differential lock and wet disc brakes, this axle provides better grip and greater stability in uneven ground conditions. This improves traction and manoeuvrability in the field and makes for faster travel speeds on the road, ensuring maximum safety and ride comfort in any situation. The 55° steering angle provides excellent manoeuvrability in confined spaces and the combined action of the front and rear wet disc brakes makes for safe and efficient braking on all four wheels.

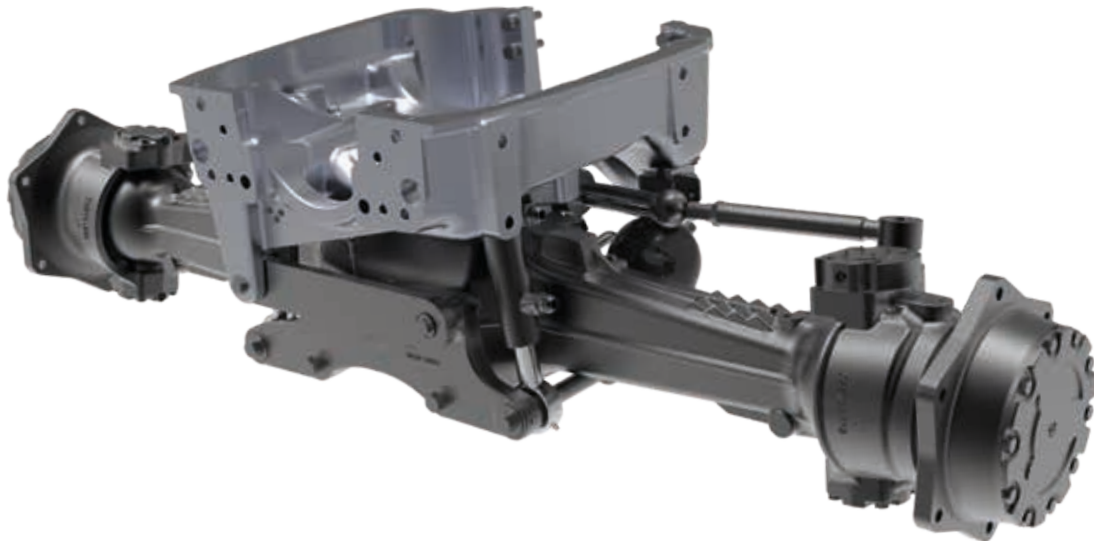

INTEGRATED BRAKE SYSTEM (IBS)

The IBS braking system with wet disc brakes integrated into the front axle provides efficient braking on all four wheels. The system reduces stopping distances by 50% ensuring maximum safety on the road. When the front and rear brakes are activated, they produce a braking force proportional to the foot pressure applied on the brake pedal, thereby ensuring safe, controlled stopping power in any situation. Integrated with the hydraulic/pneumatic trailer braking systems, the IBS system will ensure efficient braking of tractor-trailer combination for safe stopping on steep gradients.



AUTOMATIC 4WD AND DIFFERENTIAL LOCK ENGAGEMENT

The X6 range is equipped with combined front and rear differential locks to reduce wheel slip and maximise traction. The system automatically engages or disengages the differential lock and the four-wheel drive making headland turns easier and quicker for the operator.



NARROW OR LARGE FRONT AXLE

The X6 can be specified with either a narrow or large rigid-mounted front axle with or without brakes. Based on the axle width, the tractor can be fitted with different tyre sizes to suit specific needs.



HYDRAULIC SYSTEM TAILORED TO YOUR NEEDS

The X6 gives you greater versatility when using implements

Thanks to an innovative technology, the **X6** can be equipped with a front hitch without requiring additional reinforcement. This adds greater versatility to the tractor for applications using front-mounted implements.

Working with the rear hitch has never been so easy

Working with the rear hitch of the **X6** is simple and safe, thanks to the electronic management and to an ergonomically-designed intuitive console. The rear hitch has a maximum capacity of 6000 kg.

Combined applications for greater productivity

Working with rear and front implement combinations is a complicated activity that requires powerful and versatile tractors. Thanks to a technology that has enhanced the versatility of the **X6** tractor, front and rear implements can be used simultaneously, thereby increasing your efficiency and productivity.





TRUE VERSATILITY FOR GREATER PRODUCTIVITY



The X6 tractor range can be configured and customized to suit specific farmer requirements. Thanks to its versatility, this tractor can be simultaneously fitted with a front hitch and a front-end loader to further increase efficiency and productivity.

CHOICE OF TWO- OR FOUR-SPEED PTO

The rear PTO offers two speeds: 540/540e rpm or 540/1000 rpm. A four-speed PTO providing 540/540Ee/1000/1000E rpm is also available as an option. An hydraulically operated clutch enables smooth and modulated engagement of the PTO, ensuring a soft start-up of the implement. External PTO controls are located on the rear fenders making it easier to attach implements from the ground.



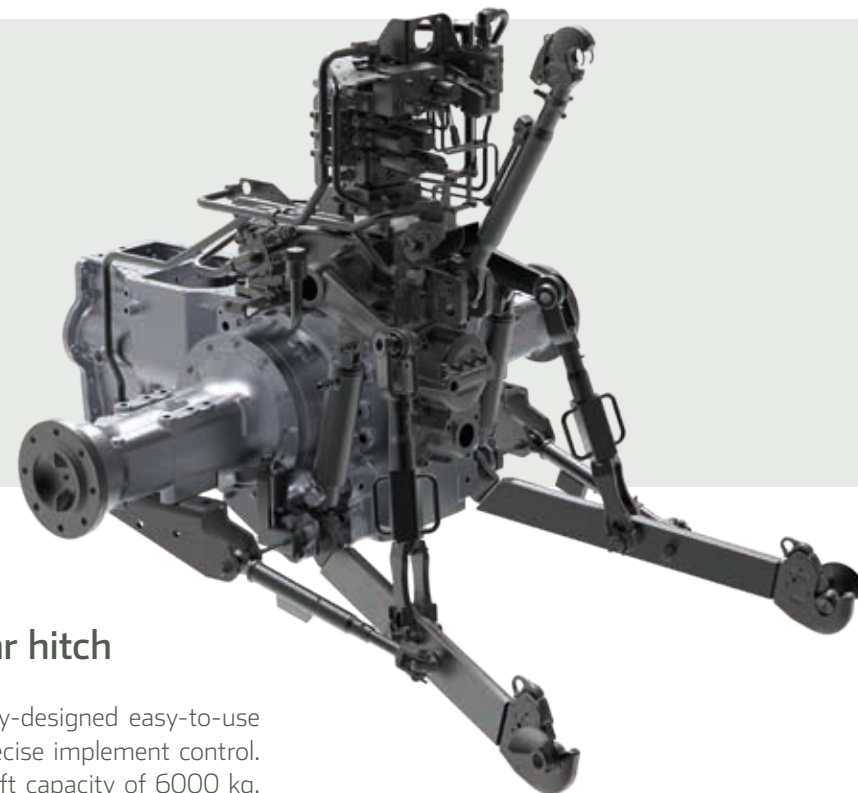

HIGHLIGHTS

- › Front hitch and PTO for maximum versatility
- › Up to 6 front- and mid-mounted remote valves



Easy-to-use electronically-controlled rear hitch

The electronically-controlled rear hitch features ergonomically-designed easy-to-use controls and is equipped with lower link draft sensing for precise implement control. The three-point hitch is Category II and offers a maximum lift capacity of 6000 kg. External hitch controls are located on the rear fenders making it easier to attach implements from the ground. The **X6** tractors are equipped with a hitch dampening function to prevent pitching when travelling with hitch-mounted implement.



AUTO PTO FUNCTION

The Auto PTO feature will automatically disengage and reengage the PTO at three-point linkage heights set by the operator. This gives the operator precise control of the implement during headland turns.



MECHANICALLY-CONTROLLED REAR HITCH

The **X6** series tractors come standard with a mechanically-controlled rear hitch that guarantees precise implement operation.

To speed up headland operations, the tractor can be optionally equipped with Ergonomic Lift System (ELS), a device allowing the implement to be automatically lifted and lowered with the simple click of a button.

HIGH-PERFORMANCE HYDRAULIC SYSTEM



The **X6** Series features an open-centre hydraulic system with a total flow of 66 l/min allowing efficient operation of all hydraulic functions. An 11-litre auxiliary oil tank is optionally available for implements requiring a large quantity of oil. A dedicated pump supplies 30 l/min to the steering system ensuring smooth and precise turning in any conditions for enhanced operator comfort and productivity.

Remote valves for every application need

The **X6** can be equipped with up to four remote valves. Three valves are mechanically operated by levers and one is controlled electro-hydraulically via a pushbutton. Two additional mid-mount remotes are available as an option for the use of M Series front loaders or other front-mounted implements.

Four types of remote valves are available that can be used in combination to suit different application needs:

- **Standard:** double-acting;
- **Kick-out:** with automatic detent release;
- **Float:** for implements that follow the contour of the ground;
- **Hydraulic motor:** for the use of hydraulic motors.

Each option allows the tractor to work with the front hitch, the front loader, the rear hitch and a variety of front- and rear-mounted implements for maximum efficiency and productivity. High-quality quick-release couplings, conveniently fitted on both the front and rear of the tractor, allow quick and easy connection/disconnection of hydraulic lines for fast operation.

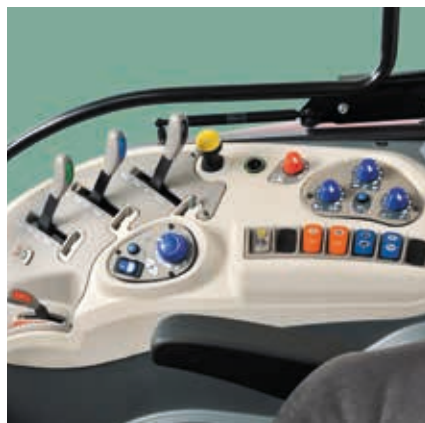
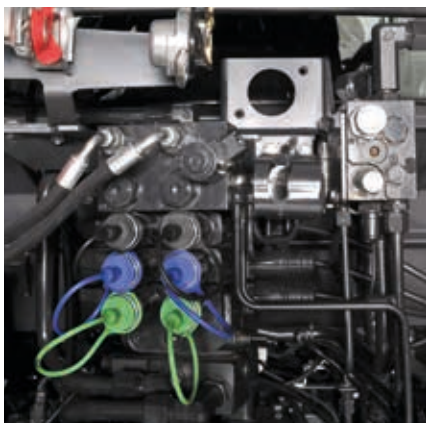

McCORMICK M SERIES FRONT LOADER: BUILT FOR POWER AND VERSATILITY



Designed to be integrated into the **X6** Series tractor range, the McCormick M80 and M100 front loaders are built from HLE (High Limit Elasticity) steel, a material capable of withstanding high loads thanks to its mechanical properties.

The main strong points of the M80 and M100 front loaders are:

- Hydraulic lines hidden inside the loader arms to ensure unobstructed view during operation;
- The piping of the hydraulic system is rigid to reduce oil overheating during intensive use and to simplify maintenance operations;
- A position indicator allows operator to quickly determine implement position;
- Used in combination with a Euro Hitch tool carrier, the loader can be fitted with a wide range of implements;

Front hitch and PTO

A front hitch and PTO are available as an option to add greater versatility to the **X6** tractor for applications using rear- and front-mounted implement combinations. Offering a maximum lift capacity of 2250 kg, the front hitch is Category II and features raise/lower and float controls. The 1000-rpm PTO is engaged via a pushbutton. External PTO and hitch controls are located on the rear fenders making it easier to attach implements from the ground.

- Maximum lift capacity of 1880 kg;
- The loader features a suspension with two nitrogen-charged accumulators placed between the cylinders that ensures a smooth ride at all times;
- The **X6** Series is equipped with supports designed to make fitting and removal of the M series loader easier;
- The M80 and M100 loaders can be used in conjunction with a front-mounted hitch.

The **X6** further features a conveniently placed controller and a high-visibility transparent roof hatch allowing the operator to comfortably sit in the driving position while working with the loader fully raised. Designed to be the perfect match for the **X6** tractor, the M Series front loaders deliver maximum productivity in any application.

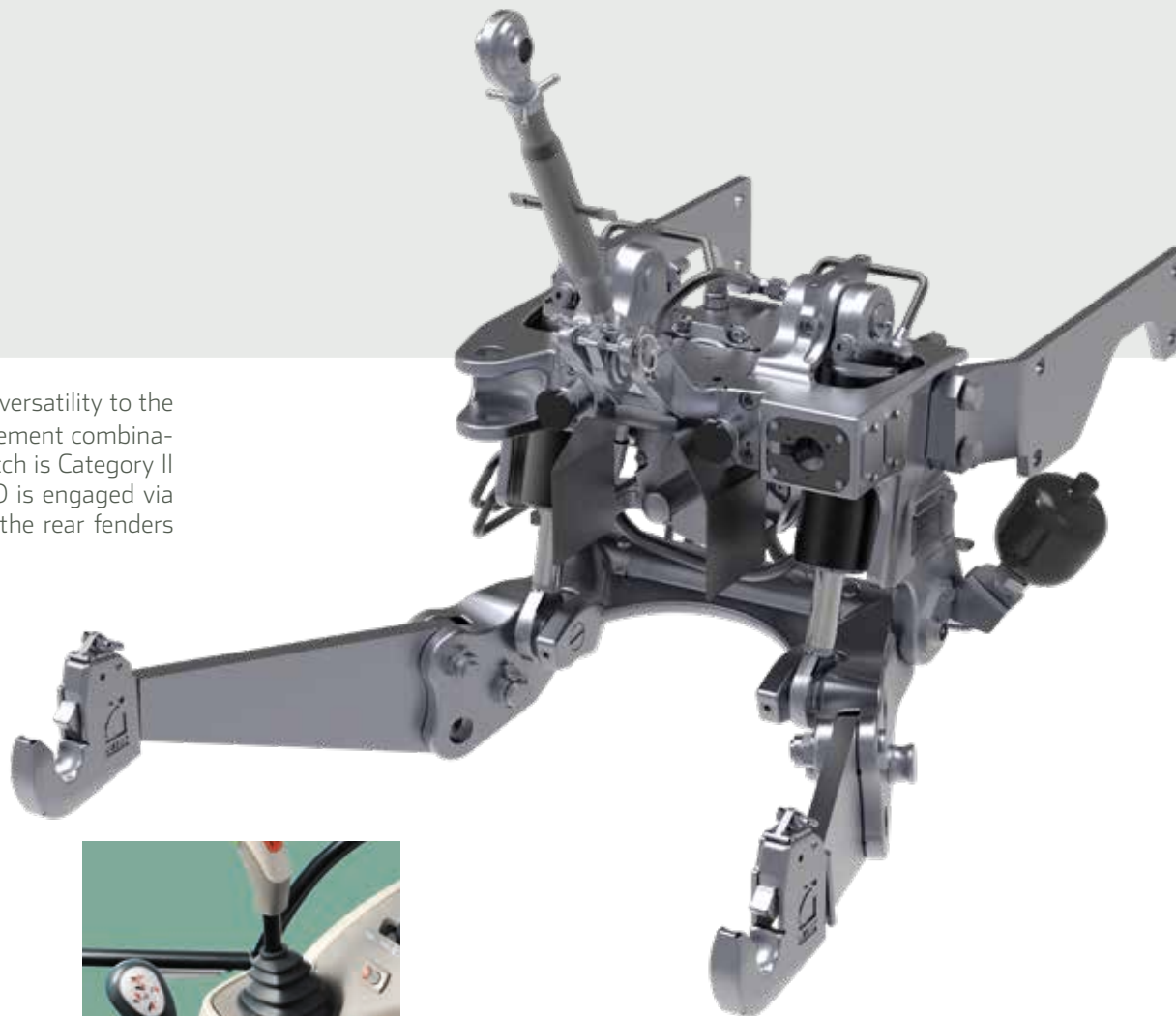





SATELLITE-BASED GUIDANCE: MORE PRODUCTIVITY AND LESS COSTS



The X6 is a cost-saving champion: with precision farming, costs are reduced by 7%
Research in the agricultural sector has demonstrated that the use of the X6 tractor in precision farming leads to saving of up to 7% on costs of fuel, equipment, fertilisers and pesticides. The satellite-based guidance system can be installed also after purchase of the X6, while keeping all the functionalities and advantages of the system unchanged.

With the satellite-based guidance you perform every task with maximum efficiency
With the ISOBUS system the operator can manage the implements without the need to install a control unit inside the cab. The implement operating parameters are monitored via a simple touch screen display.

Precision farming: when precision turns into profit
With the satellite-based guidance, the X6 makes a deviation of maximum 2 cm from the desired track: a degree of accuracy that even the most expert operators cannot achieve. Precision farming allows farmers to maximize their crop productivity and profitability.



SATELLITE GUIDANCE: THE PRECISION TOOL FOR YOUR PRODUCTIVITY

The optional satellite-based guidance system is controlled via a dedicated 8.4" touchscreen monitor in conjunction with a satellite antenna fitted on the roof of the tractor cab.

The monitor manages two functions:

1. The Precision Steering Management system, which provides precise steering control delivering up to 2cm pass-to-pass accuracy in row-crop operations. Such a high level of precision greatly increases productivity per unit land area.
2. Configuration and control of the ISOBUS system with management of advanced features such as TC-GEO.

ELECTRONIC STEERING WHEEL

The X6 Series tractors can be specified with the Topcon electronic steering wheel which allows extremely precise steering, thereby reducing operator fatigue and saving time and fuel.

SATELLITE ANTENNA

The satellite antenna placed on the cab roof receives the GPS signal.



ISOBUS SYSTEM FOR SIMPLE AND EFFICIENT IMPLEMENT CONTROL

The X6 tractor range can be optionally equipped with an ISOBUS terminal to increase operating efficiency and productivity. With the ISOBUS system, the operator manages the implements via a simple touch screen monitor, without the need to install a dedicated control unit inside the cab.



TOUCH SCREEN MONITOR

An 8.4-inch touch screen monitor manages the satellite-based guidance and the ISOBUS system.

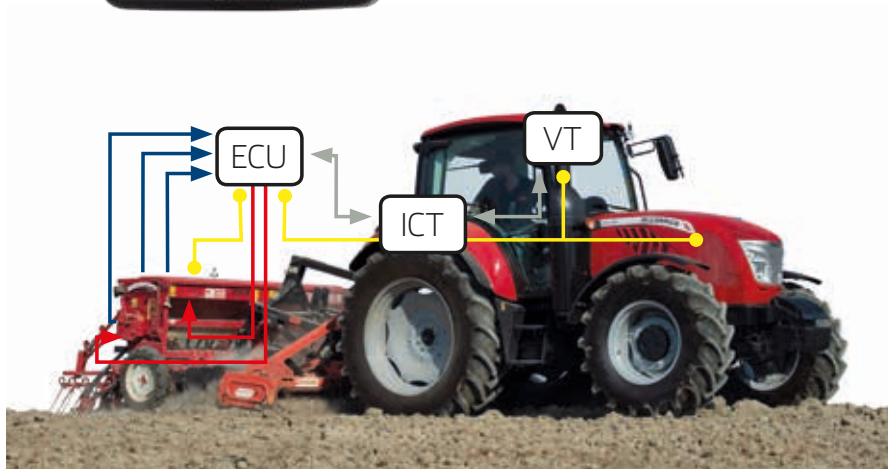

Benefits of satellite-based guidance and ISOBUS system

The satellite-based guidance and the ISOBUS system maximise efficiency and productivity while improving riding comfort and safety:

- › Each implement operation is controlled with extreme accuracy. Implement can also be managed automatically.
- › Reducing the travelled distance in the field reduces tractor and implement wear and saves fuel.
- › The application of variable rate treatments eliminates skips and overlaps; this minimizes product wastes and reduces working time while maximizing efficiency and crop yield.
- › Precision farming reduces chemical residues. For example, it makes it possible to place fertilizer only in a specific row that will be sown at a later date: at the time of seeding, the row will be found thanks to the map system of the automatic guidance.
- › Report and pre-setting operations become more user-friendly and can be done from home. This eliminates the need for expert operators, thus reducing operating costs.



QUICK MAINTENANCE TO GET YOU BACK UP AND RUNNING

- › The tilt-up hood opens wide to provide easy access to the engine compartment for maintenance.
- › Oil filler cap is placed in the lower part of the engine, so topping up of engine oil can be done without opening the hood.
- › Engine air filter is positioned in such a way as to facilitate cleaning and replacement.
- › The cooling radiators, mounted in the engine front, and the laterally-removable dust cover allow simple and fast cleaning.
- › The fuel and AdBlue® tanks are conveniently placed to allow quick filling. Tank caps have different colours.
- › In-cab air filter is easily accessible for maintenance.
- › Oil level in the transmission can be conveniently checked through the oil filler cap with dipstick placed on the rear of the tractor.
- › Windscreen wiper fluid reservoir is located on the back of the cab.

Designed to deliver maximum efficiency and reliability, the **X6** Series offers a variety of solutions to simplify and expedite maintenance.





McCORMICK SPARE PARTS AND SERVICE, TO GIVE YOU THE BEST ALWAYS

McCormick is worldwide recognized as a reliable supplier of high-quality spare parts and after-sales services. Developed by the same engineers who design and manufacture the McCormick tractors, genuine McCormick parts are designed and manufactured to the highest quality standards to ensure tractors reliable performance and maximum safety.

The pluses of McCormick's after-sales service include following:

- Spare parts are delivered promptly and efficiently to McCormick's dealers on the same day of order.

- Each part comes with a 12-month warranty and bears a non-falsifiable hologram which certifies its build quality and genuineness.

- Original McCormick parts are reliable and convenient, as they enhance the working quality and efficiency of the **X6** tractors.

After-sales service is handled by our dealers through a team of highly-skilled, solution-oriented technicians who avail themselves of the latest diagnostic techniques. Choosing McCormick means choosing excellence.





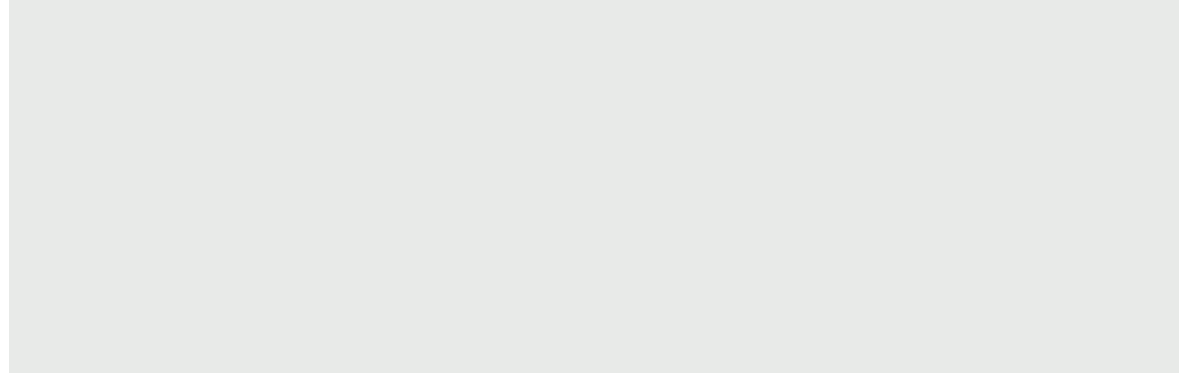

McCORMICK, INNOVATORS BY TRADITION



Cyrus Hall McCormick was born in Virginia, United States, in 1809. As a pioneer in engineering, McCormick had a stunning ability to mechanize farm work, as he demonstrated when, in 1831, he invented the first mechanical reaper. The McCormick company was established in 1847. It produced wheat harvesters. Starting from 1866, the company adopted the colour red which from then on would distinguish McCormick around the world. In 1871, McCormick manufactured the greatest number of machines than any other company: 250 reapers per day. The first tractor, the Mogul 8-16, was launched in 1910. In those years, the company opened up factories in Canada, Great Britain, Germany, France and Sweden. In the following years, the company was bought and sold various times. In 2001, McCormick was acquired by the Argo Group, which re-launched the brand under the name McCormick Tractors International Limited. Today, McCormick is a world leader in the tractor industry and its name stands for uncompromised technology and innovative design. Thanks to heavy investments in research and development, the new generation of McCormick tractors is now positioned at the top of the market for performance and innovation. Farmers look for performance, reliability and versatility and this is exactly what McCormick offers its customers to maximize their productivity.



ARGO TRACTORS: QUALITY OF WORK, QUALITY OF LIFE

Picking up and revitalizing the wealth of experience and technology of companies that have made the history of mechanized farming. This is the commitment of Argo Tractors SpA, the industrial group that with the Landini, McCormick and Valpadana brands has created a global tractor manufacturing hub. Argo Tractors' strategy is based on close integration between engineering, manufacturing and marketing activities. The R&D and engineering division is located at the main headquarters in Fabbrico (Reggio Emilia). The production is based on the synergy between three plants, each of which dedicated to a specific product line, and two spare parts distribution centres based in Italy and the United States.

Today, with the Landini, McCormick and Valpadana brands, Argo Tractors offers one of the most comprehensive product ranges on the market, covering 3-, 4- and 6-cylinder tractor families in the power range from 25 to over 310 hp for a variety of open-field, vineyard and orchard applications, including crawler, utility and equal-wheeled tractors. But more importantly, at the heart of Argo Tractors' project is man, with the company's commitment to respect the environment and make the daily work of farmers safer and more comfortable.





		X6.35	X6.45	X6.55
ENGINE				
STAGE 4 / TIER 4 FINAL		DEUTZ -AG	DEUTZ -AG	DEUTZ -AG
MAX POWER ISO	HP/KW	110 / 81	119 / 88	126 / 93
RATED POWER ISO	HP/KW	105 / 77	113 / 83	120 / 88
RATED ENGINE SPEED	RPM	2200	2200	2200
MAX TORQUE	NM	440	476	500
MAX TORQUE SPEED	RPM	1600	1600	1600
BORE / STROKE	MM	98/120	98/120	98/120
DISPLACEMENT / CYLINDERS	CM ³	3600 / 4 TA	3600 / 4 TA	3600 / 4 TA
SCR + DOC AFTER-TREATMENT SYSTEM		●	●	●
ADBLUE TANK CAPACITY	L	20	20	20
FUEL TANK CAPACITY	L	150	150	150
CLUTCH				
MULTI-DISC WET CLUTCH		●	●	●
DE-CLUTH CONTROL: BUTTON-OPERATED CLUTCH		●	●	●
TRANSMISSION				
SPEED FOUR + POWER SHUTTLE: 12FWD + 12REV 40 KM/H		●	●	●
SPEED FOUR + CREEPER + POWER SHUTTLE: 16FWD + 16REV 40 KM/H		○	○	○
XTRASHIFT + SPEED FOUR + POWER SHUTTLE: 36FWD + 12REV (3-STAGE POWERSHIFT)		○	○	○
XTRASHIFT + SPEED FOUR + CREEPER + POWER SHUTTLE: 48FWD + 16REV		○	○	○
REVERSE POWER SHUTTLE		●	●	●
SHUTTLE MODULATION CONTROL: ADJUSTMENT OF POWER SHUTTLE RESPONSE		●	●	●
PARK LOCK		○	○	○
POWER TAKE-OFF				
WET MULTI-DISC PTO CLUTCH		●	●	●
ELECTROHYDRAULIC ENGAGEMENT		●	●	●
2 SPEEDS: 540/540E RPM		●	●	●
2 SPEEDS: 540/1000 RPM		○	○	○
4 SPEEDS: 540/540E/1000/1000E RPM		○	○	○
1 ³ / ₈ PTO SHAFT WITH 6 SPLINES		●	●	●
1 ³ / ₈ PTO SHAFT WITH 21 SPLINES		○	○	○
GROUND SPEED PTO		○	○	○
FRONT 4WD AXLE				
ELECTROHYDRAULIC 4WD ENGAGEMENT		●	●	●
RIGID TYPE		●	●	●
WITH ELECTRONICALLY-CONTROLLED HYDRAULIC SUSPENSIONS		○	○	○
MAX STEERING ANGLE		55°	55°	55°
TWIN-LOCK ELECTROHYDRAULIC DIFFERENTIAL LOCK		●	●	●
BRAKING SYSTEM				
HYDROSTATICALLY-OPERATED ANNULAR PISTON BRAKES		●	●	●
AUTOMATIC 4WD ENGAGEMENT ON BRAKING		●	●	●
WET MULTI-DISK FRONT BRAKES		○	○	○
INTEGRAL BRAKING SYSTEM - IBS		●	●	●
HYDRAULIC TRAILER BRAKING		○	○	○
PNEUMATIC TRAILER BRAKING		○	○	○
HYDRAULIC SYSTEM				
DRAFT, POSITION, MIXED AND FLOAT CONTROL		●	●	●
MECHANICALLY-CONTROLLED REAR HITCH		○	○	○
ERGONOMIC LIFT SYSTEM		○	○	○

		X6.35	X6.45	X6.55
HYDRAULIC SYSTEM				
ELECTRONICALLY-CONTROLLED REAR HITCH		○	○	○
LIFT CAPACITY WITH 2 ASSISTOR RAMS	KG	6000	6000	6000
MAX WORKING PRESSURE	BAR	200	200	200
PUMP FLOW RATE (HITCH+STEERING)	L/MIN	66 + 30	66 + 30	66 + 30
AUXILIARY OIL TANK	L	11	11	11
THREE-POINT HITCH CATEGORY 2		●	●	●
HYDRAULIC ADJUSTMENT OF RIGHT LIFTING ROD AND TOP LINK		○	○	○
REMOTE VALVES STD / OPT		2- 4	2- 4	2- 4
FRONT HITCH AND PTO (MAX LIFT CAPACITY)	KG	2250	2250	2250
CAB AND DRIVING POSITION				
DELUXE SLIM CAB / RADIO ADAPTOR		●	●	●
MECHANICAL CAB SUSPENSION		○	○	○
HEATING / VENTILATION		●	●	●
AIR-CONDITIONING		●	●	●
AIR SUSPENSION SEAT		○	○	○
RADIO / BLUETOOTH / MP3 READY		○	○	○
DIGITAL INSTRUMENT PANEL		●	●	●
ISOBUS ADAPTOR		○	○	○
SATELLITE GUIDANCE KIT (8.4" TOUCH SCREEN MONITOR + ANTENNA)		○	○	○
DIMENSIONS AND WEIGHTS				
A - MAX LENGTH 4WD (WITH BALLAST WEIGHTS)	MM	4176	4176	4176
B - MIN WIDTH	MM	2075	2075	2075
C - WHEELBASE	MM	2420	2420	2420
D - HEIGHT OVER CAB	MM	2650	2650	2650
E - GROUND CLEARANCE	MM	420	420	420
WEIGHT IN RUNNING ORDER (WITHOUT BALLAST WEIGHTS)	KG	4600	4600	4600
OPTIONAL EQUIPMENT				
N. 10 FRONT BALLASTS 42 KG EACH		○	○	○
WEIGHT FOR FRONT HITCH 300 KG		○	○	○

Key: ● standard ○ option — not available

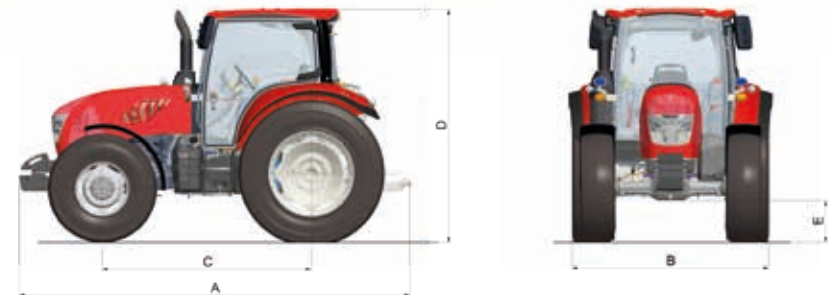



Power Technology.

via G. Matteotti, 7 | 42042 Fabbrico [RE] Italia | t. +39.0522.656.111 | f. +39.0522.656.476
webmaster@argotracors.com | www.argotracors.com



graphic design: **gruppo saldatori** | bzzbzz@grupposaldatori.com
All data and illustrations provided in this brochure are for information purposes only and can be changed without notice.

GB
6636947A1