

# X5



35 - 45 - 55





# McCORMICK X5, THE PERFECT ALL-ROUNDER

A pioneer of agricultural mechanization, Cyrus Hall McCormick started a tradition of technological innovation that continues to this day with the Argo Tractors Group. Driven by a strong commitment to quality, Argo Tractors engineers have developed a truly innovative range of high-performance utility tractors that has no equal on the market for simplicity, versatility, cost-effectiveness and ease of maintenance.

The **X5** is the new generation of McCormick's compact tractors for field work. Designed with versatility in mind, the **X5** will allow farmers to carry out in complete safety a variety of tasks both in the field and on the farm, from tillage, sowing and haymaking to barn management activities. Engineered and built to handle all daily operations in the farm with total reliability and maximum comfort, the **X5** tractor is the perfect choice for medium-scale stand-alone farms.

The **X5** tractor is highly versatile and completely customizable to meet farmers' specific needs. Tractor key features include:

- A four-post cab with ergonomically-positioned controls for maximum ease of operation and a transparent roof hatch providing extra visibility for front loader operations. The low-profile roof allows easier access to low-ceiling barns and

sheds. The **X5** tractor can be optionally equipped with a satellite-based guidance system and an ISOBUS terminal to maximize productivity and profitability.

- New Deutz AG 3.6L engines with power ratings of up to 113 hp. These engines meet the Stage 3B/Tier 4 Interim emissions regulations using a diesel oxidation catalyst (DOC).

- Transmission options range from a basic Speed Four gearbox with synchro shuttle providing 12 forward and 12 reverse speeds up to an Xtrashift three-stage powershift (high, medium, low) with creeper providing 48 forward and 16 reverse speeds.

- The four-wheel drive, the differential lock and the PTO, with either two or four speeds, are electro-hydraulically engaged.

- The open-centre hydraulic system ensures optimum operation of the rear hitch and of up to five remote valves.

- Optionally, the **X5** can be fitted with a front hitch and PTO system and an M Series front loader.

The name McCormick has always stood for innovation. Choosing McCormick means you can count on a reliable partner that gives you state-of-the-art technology and unmatched versatility without compromising on simplicity.

# HIGHLIGHTS

## Cab

- › Deluxe Slim cab: unequalled all-round visibility, ergonomic controls and high-quality fit and finish
- › Driver's seat with optional air suspension system
- › Low-profile cab roof for easy access to low-ceiling barns and sheds
- › 8.4-inch touch screen monitor for satellite guidance and ISOBUS control

## Engine

- › Deutz AG 3.6L engine delivering up to 113 hp
- › Exhaust gas after-treatment with DOC system to meet Stage 3B/Tier 4 Interim emissions regulations

## Transmission

- › Power Four transmission with two-stage Hi-Lo Powershift
- › Xtrashift transmission with three-stage HML Powershift

## Axle

- › Rigid front axle with full locking differential and electro-hydraulic four-wheel drive engagement

## Hydraulic system

- › Open-centre hydraulic system with 62 l/min flow rate
- › Rear hitch with up to 4500 kg lift capacity
- › Rear 4-speed PTO optional



**EXHAUST SYSTEM**

emissions under control  
page 13

**SATELLITE-BASED GUIDANCE**

higher accuracy, greater productivity  
page 32

**CAB**

perfect visibility  
and first-class comfort  
page 6

**HYDRAULIC SYSTEM**

innovative, for maximum  
configuration flexibility  
page 22

**ISOBUS**

simple and efficient  
implement control  
page 33

**ENGINE**

a new heart  
page 10



**FRONT AXLE**

for unmatched manoeuvrability  
page 20

**TRANSMISSION**

versatile and tailored  
to suit every need  
page 14

**ELECTRONIC HITCH**

powerful and easy to use  
page 25

# THE **X5** MAKES EVERY JOB EASY

## **Just easy: in-built simplicity**

The controls inside the Deluxe Slim cab are designed with simplicity in mind to reduce operator fatigue and stress. Not only the cab, but also the whole tractor has been designed and built for ease of use and efficiency. You don't need to be an engineer to use this tractor, because the McCormick **X5** is just easy.

## **The cab's panoramic view gives you the sensation that you are outside**

The Deluxe Slim cab offers a spacious, fully-glazed working environment and a transparent roof hatch that give the operator perfect all-round visibility, making front loader operations and manoeuvres in tight spaces, where unobstructed view at close range is paramount, easier and safer.

## **Deluxe Slim cab: simple and functional, with all comforts at your fingertips**

Equipped with all you need to work efficiently, the Deluxe Slim cab turns simplicity into efficiency. Perfectly sound-insulated, the cab interior features an automotive-style fit and finish and a highly-efficient automatic climate control that maintains an ideal cab temperature whatever the outdoor weather conditions. The driving position is equipped with a telescopic, tilt-adjustable steering wheel, a Bluetooth radio and a hands-free phone. A simple, functional cab for a perfect all-rounder.





# NEW DELUXE SLIM CAB: PLENTY OF ROOM FOR ULTIMATE COMFORT



Specially designed for the **X5** tractor range, the new Deluxe Slim cab helps reduce operator stress and fatigue during long working days. Spacious and perfectly soundproofed, the cab interior features an automotive-grade fit and finish with soft-touch, easy-clean materials.

And that's not all: a highly efficient heating, ventilation and air conditioning system, conveniently built into the low-profile cab roof, maintains a comfortable working environment whatever the outdoor weather conditions.

The front and rear windscreens can be opened to provide natural ventilation. With its superb all-round visibility, the Deluxe Slim cab makes manoeuvring in tight spaces and at headlands easier and safer, while the transparent roof hatch provides extra visibility for loader operations.

## **ACCESS TO DRIVING POSITION**

Fully glazed rear-hinged doors provide easy access to the driving position. Wide, sturdy access steps and handrails fitted to the cab posts and to the doors allow operators to safely climb up and down the tractor..



## HIGHLIGHTS

- › McCormick's latest design with aggressive, contemporary looks
- › Telescopic steering wheel tilting with instrument panel
- › Highly-efficient climate control thanks to the roof-integrated air-conditioning system
- › Opening transparent roof hatch for extra visibility during front loader operations
- › Six work lights for proper illumination during night work



### DRIVER SEAT AND HIDE-AWAY BUDDY SEAT

Large and comfortable, the driver seat is available with either mechanical or air suspension system that can be adjusted to suit the driver's weight. Passengers can also travel in comfort thanks to an upholstered buddy seat, which neatly folds away to allow easier access to the cab.



### INSTRUMENT PANEL AND STEERING WHEEL

The steering wheel is telescopic and tilt adjustable. The instrument panel, which tilts with the steering column, features easy-to-read digital and analog instruments for easy monitoring of tractor functions.



### AIR CONDITIONING AND OPENING ROOF HATCH

The heating, ventilation and air conditioning system, integrated into the cab roof, maintains a comfortable working environment whatever the outdoor weather conditions. The front and rear windscreen and the roof hatch can be opened to allow natural ventilation.



### BLUETOOTH RADIO

The Bluetooth AM/FM radio enables listening to music also through an MP3 player, an AUX cable or a USB flash drive, while an integrated microphone allows the driver to make hands-free phone calls.





# FUEL ECONOMY AND LOW MAINTENANCE: THE X5 IS GREAT VALUE FOR MONEY

## **The X5 is fuel economy champion in its class!**

The McCormick **X5** has ultra low fuel consumption for the power developed. This is due to the lack of an exhaust gas regeneration system and to the presence of the Engine Memo Switch, a device that allows operator to store and recall the engine speed most suited to the implement used.

## **Quick and easy maintenance to save time**

All main components are quick and simple to check and maintain and can be easily accessed by simply raising the hood of the **X5**. Also, service intervals are extended and all major maintenance operations can be carried out quickly without removing any parts.

## **Total safety when working in closed environments**

The post-combustion process, achieved through the injection of additional fuel, breaks up the particulate matter retained in the diesel particulate filter (DPF), thereby reducing its harmful effects on human beings and the environment. However, as the DPF is connected to the exhaust muffler, during post-combustion some sparks of incandescent particulate matter might be ejected and fall onto dried powders, forage or straw causing damage or hazard to people. The McCormick **X5** is equipped with a diesel oxidation catalyst (DOC) which eliminates the need for a DPF, making daily activities within barns and sheds totally safe.





# DEUTZ AG ENGINE: TIRELESS, RELIABLE, COST-EFFICIENT

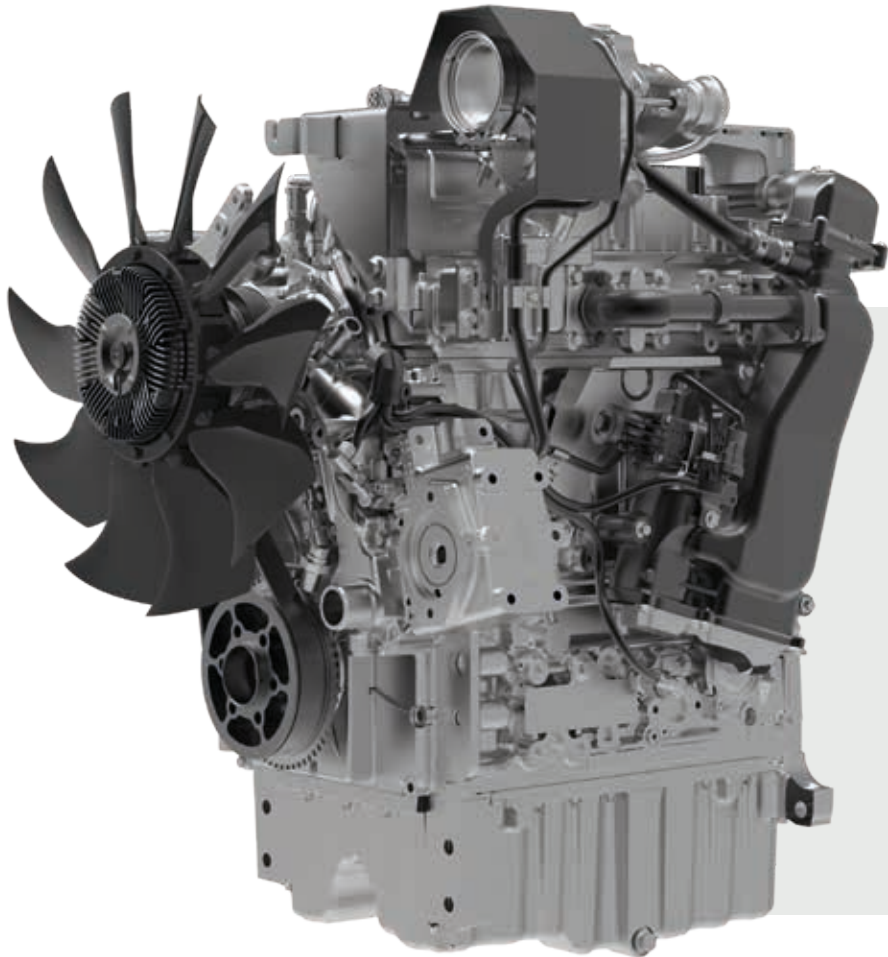

The three models of the **X5** Series are all powered by cutting-edge Deutz AG 3.6L four-cylinder turbo engines with multivalve technology, intercooler and common rail injection system. These innovative engines meet the Stage 3B/Tier 4 Interim emissions regulations using a diesel oxidation catalyst (DOC).

## Fuel economy

The Deutz AG engines that power the **X5** series are equipped with common rail, a computerized fuel injection system that provides a precisely measured amount of fuel to the engine, thereby reducing consumption while maximizing performance. Fuel efficiency is further enhanced with the Engine Memo Switch, a device that allows the operator to store and recall the engine speed most suited to the implement used. The **X5** tractor is equipped with a 120-litre fuel tank to ensure extended operation without refuelling.

## DOC system to keep exhaust emissions under control

The X5 is equipped with an innovative diesel oxidation catalyst (DOC) which does away with exhaust gas regeneration, thereby eliminating the need for a diesel particulate filter (DPF). The DOC system ensures compliance with the Stage 3B/Tier 4 Interim emissions regulations.



McCORMICK X5	POWER HP	POWER KW	MAX TORQUE
35	99	73	397
45	107	79	420
55	113	83	460





# A TRANSMISSION YOU CAN RELY ON IN ANY SITUATION



## **Choose a transmission that's suited to your needs**

Designed with versatility in mind, the **X5** tractor can be customized by choosing from a variety of transmission configurations designed to offer tailored solutions for each farmer's specific needs. All McCormick transmissions share a distinctive feature: they are derived from higher-class machines and are therefore designed to provide top-notch performance combined with extended life and superior reliability under all operating conditions.

## **Never more power losses!**

When travelling either on the road, on mixed terrain or on sloping ground, the transmission of the **X5** will allow you to maintain a constant power under varying load conditions, while keeping tractor performance unaltered.

## **Get maximum efficiency and ultimate comfort with the X5**

From mechanical to latest-generation Powershift transmissions, all McCormick transmissions are designed to deliver maximum efficiency and ultimate operator comfort. Thanks to this design philosophy, the **X5** will ensure excellent performance in any conditions.

# A TRANSMISSION **TAILORED** TO EACH FARM'S NEEDS

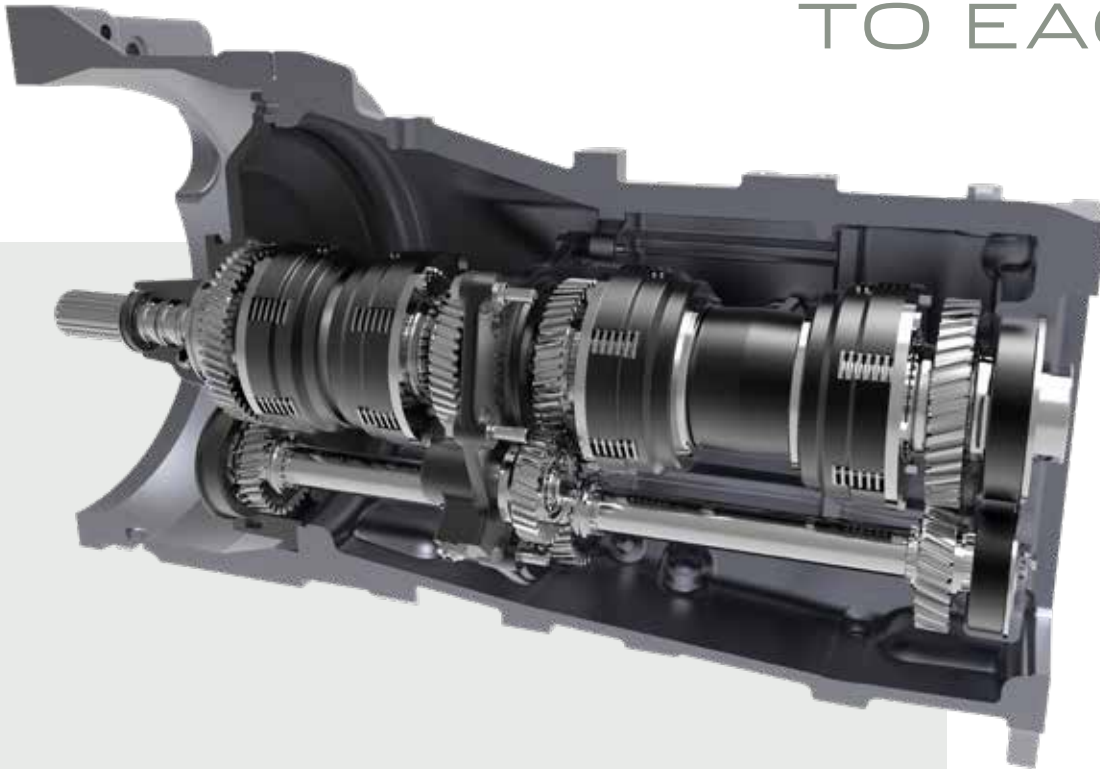

A variety of transmission configurations allow the **X5** to better meet the specific needs of each farm, further enhancing the tractor versatility. Options available range from a basic 12/12 Speed Four transmission with synchro shuttle up to an electrohydraulic 48/16 Xtrashift transmission with HML powershift and creeper.

Up to eight different configurations are available:

1. Speed Four with synchro shuttle providing 12FWD + 12REV speeds.
2. Speed Four with synchro shuttle and creeper providing 24FWD + 24REV speeds.
3. Power Four with Hi-Lo splitter and synchro shuttle for a total of 24FWD + 24REV speeds.
4. Power Four with Hi-Lo splitter, synchro shuttle and creeper for a total of 32FWD + 32REV speeds.
5. Power Four with Hi-Lo splitter and power shuttle providing 24FWD + 24REV speeds.
6. Power Four with Hi-Lo splitter, power shuttle and creeper for a total of 32FWD + 32REV speeds.
7. Xtrashift with HML Powershift and power shuttle for a total of 36FWD + 12REV speeds
8. Xtrashift with HML Powershift, power shuttle and creeper for a total of 48FWD + 16REV speeds.



## Speed Four transmission

The Speed Four transmission with left-hand steering-column synchro shuttle is the basic configuration on the X5 tractor range. It features four synchronized speeds and three ranges providing 12 forward and 12 reverse gears and can be equipped with a creep speed option providing a total of 16 forward and 16 reverse gears with speeds as low as 310 m/h.

## Power Four electrohydraulic transmission for total reliability

The Power Four electrohydraulic Hi-Lo transmission doubles the gears of the basic transmission providing 24 forward and 24 reverse speeds. The creep speed option further increases the number of available speeds to 32 forward and 32 reverse. The Power Four transmission can be specified with either a synchro or power shuttle with lever adjacent to the steering wheel. In addition, a De-clutch control function allows the operator to shift through all gears without using the clutch pedal.

## Xtrashift electrohydraulic transmission for maximum efficiency

The Xtrashift transmission is a 3-stage Powershift (H-M-L) that triples the 12 gears of the Speed Four transmission providing 36 forward and 12 reverse speeds for maximum efficiency in the field and on the road. An optional creep speed unit provides up to 48 forward and 16 reverse gears and allows for speeds as low as 310 m/h. The De-clutch button and the power shuttle allow the operator to shift through all gears and change from forward to reverse without using the clutch pedal. The shuttle response is electronically modulated and adjustable by the operator if required for different tasks.



### PARK LOCK, SAFETY GUARANTEED

The power shuttle transmission can be optionally equipped with Park Lock, a mechanical locking device which locks the transmission for added safety when parking the tractor on steep inclines.





# McCORMICK X5, BUILT FOR LIGHTNESS

## **With the X5 tractor, you will say goodbye to soil compaction**

The X5 minimizes soil compaction through proper weight distribution: 45% in the front and 55% to the rear. This optimum weight distribution between the two axles makes the X5 the best balanced tractor in its power class.

## **The X5 reduces stress and helps you stay focused on your job**

If you are looking for a tractor that is easy to drive and operate, then the X5 is the right thing for you. While driving the X5, you do not need to continuously correct the vehicle direction of travel, so you can better concentrate on the job in hand and at the end of the day you will feel less fatigued.

## **Spring-on system for best four-wheel drive performance**

The Spring-on system is designed to provide powerful, efficient four-wheel drive in any situation, thereby preventing slippage and allowing greater concentration on the task in hand.



## Power, control and simplicity for best performance

The X5 series offers outstanding traction and manoeuvrability ensuring optimum grip and stability on all terrains for superior driving comfort. The rugged front axle is equipped with Twin Lock full locking differential and electro-hydraulic four-wheel drive engagement. This ensures maximum efficiency and safety in any condition, including when working with a front hitch or a front loader. The rear axle, derived from higher class vehicles, is sturdy and reliable. With its large front axle swing, its excellent ground clearance and a steering angle of 55 degrees, the X5 tractor is highly manoeuvrable in any situation, while the hydrostatic drive delivers smooth steering control even at low engine rpm.

### **AUTOMATIC 4WD AND DIFFERENTIAL LOCK ENGAGEMENT**

The X5 range is equipped with combined front and rear differential locks to reduce wheel slip and maximize traction. The system automatically engages or disengages the differential lock and the four-wheel drive making headland turns easier and quicker for the operator.



### **INTEGRATED BRAKE SYSTEM (IBS)**

The IBS braking system with wet disc brakes integrated into the front axle provides efficient braking on all four wheels. The system reduces stopping distances by 50% ensuring maximum safety on the road. When the front and rear brakes are activated, they produce a braking force proportional to the foot pressure applied on the brake pedal, thereby ensuring safe, controlled stopping power in any situation. Integrated with the hydraulic/pneumatic trailer braking systems, the IBS system will ensure efficient braking of tractor-trailer combination for safe stopping on steep gradients.





# THE HYDRAULIC SYSTEM IS CONFIGURED PRECISELY FOR YOUR NEEDS

## **The X5 tractor shows its versatility when you use the implements**

Thanks to an innovative technology, the **X5** can be equipped with a front hitch without requiring additional reinforcement. This adds greater versatility to the tractor for applications using front-mounted implements.

## **Using the rear hitch has never been so easy**

Working with the rear hitch of the **X5** is simple and safe, thanks to the electronic management and to an ergonomically-designed intuitive console. The rear hitch has a maximum lift capacity of 4500 kg.

## **Using rear and front implement combinations increases efficiency**

Working with rear and front implement combinations is a complicated activity that requires powerful and versatile tractors. Thanks to a technology that has enhanced the versatility of the **X5** tractor, front and rear implements can be used simultaneously, thereby increasing your efficiency and productivity.





# GREAT VERSATILITY FOR ADDED PRODUCTIVITY AND SATISFACTION



The X5 tractor range can be configured and customized to suit farmer's application needs. Thanks to its versatility, this tractor can be simultaneously fitted with a front hitch and a front loader that can be used in combination with rear implements for added productivity.



## **MECHANICALLY-CONTROLLED REAR HITCH**

The X5 series tractors come standard with a mechanically-controlled rear hitch that guarantees precise implement operation. To speed up headland operations, the tractor can be optionally equipped with Ergonomic Lift System (ELS), a device allowing the implement to be automatically lifted and lowered with the simple click of a button.



## HIGHLIGHTS

- › Front hitch and PTO for maximum versatility
- › Up to 5 rear- and mid-mounted remote valves

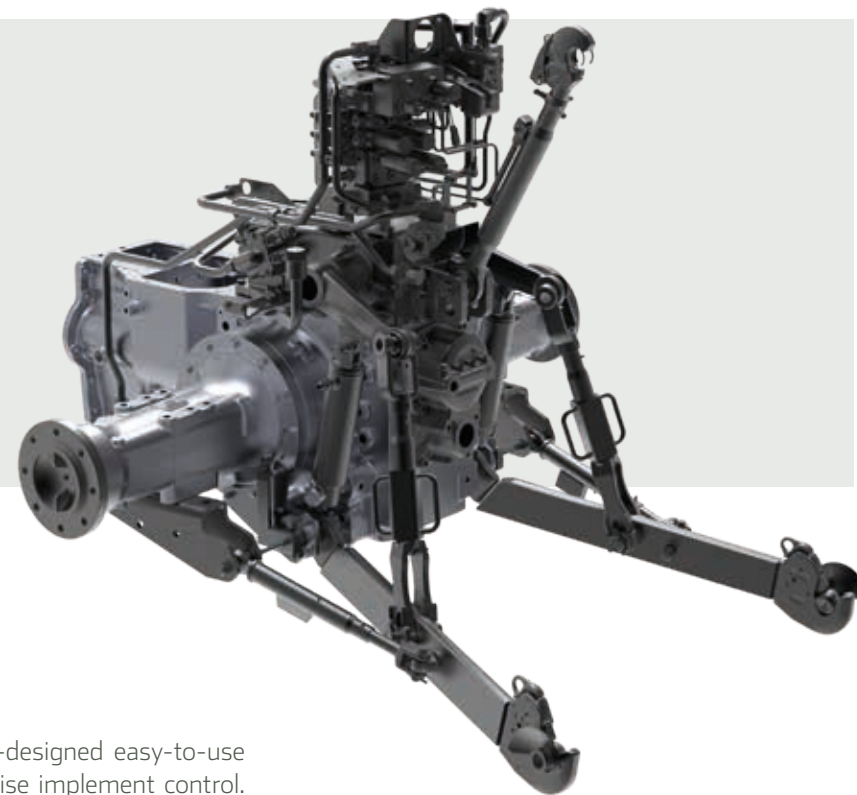

### Easy-to-use electronically-controlled rear hitch

The electronically-controlled rear hitch features ergonomically-designed easy-to-use controls and is equipped with lower link draft sensing for precise implement control. The three-point hitch is Category II and offers a maximum lift capacity of 4500 kg. External hitch controls are located on the rear fenders making it easier to attach implements from the ground.



### CHOICE OF TWO- OR FOUR-SPEED PTO

The rear PTO offers two speeds: 540/540 rpm or 540/1000 rpm. A four-speed PTO providing 540/540Ee/1000/1000E rpm is also available as an option. An hydraulically operated clutch enables smooth and modulated engagement of the PTO, ensuring a soft start-up of the implement. External PTO controls are located on the rear fenders making it easier to attach implements from the ground.

# HIGH-PERFORMANCE HYDRAULIC SYSTEM



The **X5** tractor range features an open-centre hydraulic system with a total flow of 62 l/min allowing efficient operation of all hydraulic functions. A dedicated pump supplies 32 l/min to the steering system ensuring smooth and precise turning in any conditions for enhanced operator comfort and productivity.

## Remote valves for maximum efficiency

The X5 can be equipped with up to five remote valves. Three valves are mechanically operated by levers integrated into the right-hand console. Two additional mid-mount remotes are available as an option for the use of M Series front loaders or other front-mounted implements.

Four types of remote valves are available that can be used in combination to suit different application needs:

- **Standard:** double-acting;
- **Kick-out:** with automatic detent release;
- **Float:** for implements that follow the contour of the ground;
- **Hydraulic motor:** for the use of hydraulic motors.

Each option allows the tractor to work with the front hitch, the front loader, the rear hitch and a variety of front- and rear-mounted implements for maximum efficiency and productivity. High-quality quick-release couplings, conveniently fitted on both the front and rear of the tractor, allow quick and easy connection/disconnection of hydraulic lines for fast operation.

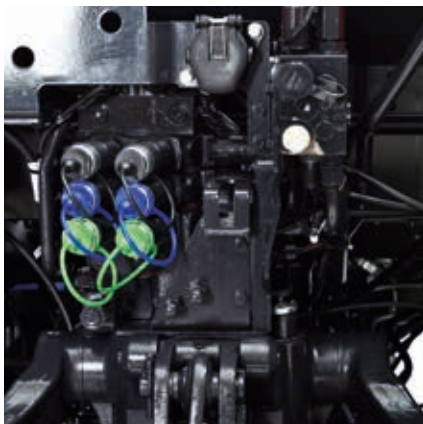

# McCORMICK M80 FRONT LOADER: BUILT FOR POWER AND VERSATILITY



Designed to be integrated into the **X5** Series tractor range, the McCormick M80 front loader is built from HLE (High Limit Elasticity) steel, a material capable of withstanding high loads thanks to its mechanical properties.

The main strong points of the M80 front loader are:

- Hydraulic lines hidden inside the loader arms to ensure unobstructed view during operation;
- The piping of the hydraulic system is rigid to reduce oil overheating during intensive use and to simplify maintenance operations;
- A position indicator allows operator to quickly determine implement position;
- Used in combination with a Euro Hitch tool carrier, the loader can be fitted with a wide range of implements;

## Front hitch and PTO

A front hitch and PTO are available as an option to add greater versatility to the X5 tractor for applications using rear- and front-mounted implement combinations. Offering a maximum lift capacity of 2200 kg, the front hitch is Category II and features raise/lower and float controls. The 1000-rpm PTO is engaged via a pushbutton. External PTO and hitch controls are also located on the rear fenders making it easier to attach implements from the ground.

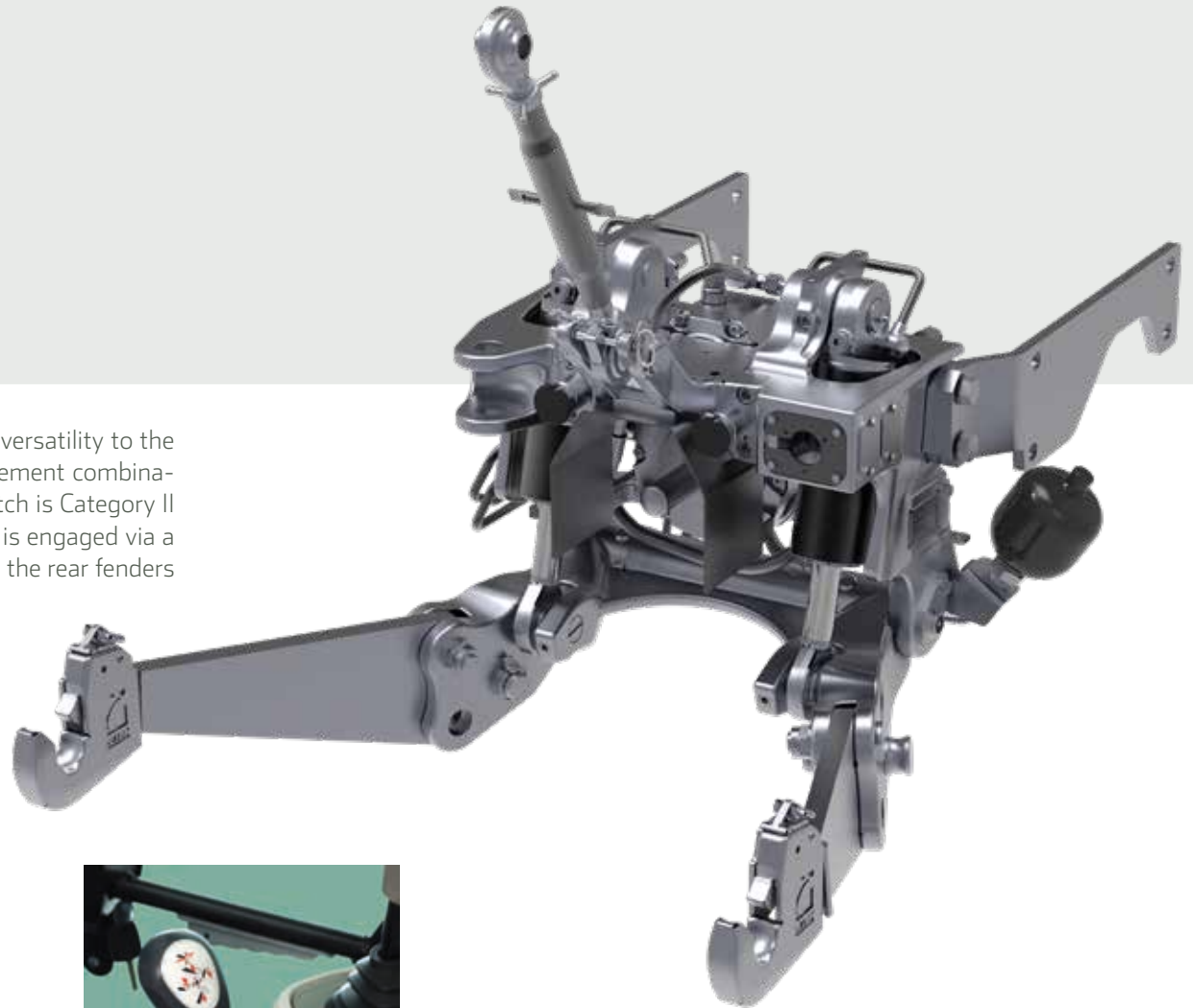

- Maximum lift capacity of 1810 kg;
- The loader features a suspension with two nitrogen-charged accumulators placed between the cylinders that ensures a smooth ride at all times;
- The X5 series is equipped with supports designed to make fitting and removal of the front loader easier;
- The M80 loader can be used even when the tractor is equipped with a front-mounted hitch.

The X5 further features a conveniently placed joystick and a high-visibility transparent roof hatch allowing the operator to comfortably sit in the driving position while working with the loader fully raised. Designed to be the perfect match for the X5 tractor, the M80 front loader delivers maximum productivity in any application.







# THE SATELLITE-BASED GUIDANCE ADDS MORE VALUE TO YOUR WORK



## **The satellite-based guidance reduces your costs by 7%**

Research in the agricultural sector has demonstrated that the use of the **X5** tractor in precision farming leads to savings of up to 7% on costs of fuel, equipment, fertilisers and pesticides. The satellite-based guidance system can be installed also after purchase of the **X5**, while keeping all the functionalities and advantages of the system unchanged.

## **The satellite-based guidance makes your work easier**

With the ISOBUS system the operator can manage the implements without the need to install a control unit inside the cab. The implement operating parameters are monitored via a simple touch screen display.

## **Precision farming turns precision turns into profit**

With the satellite-based guidance, the **X5** makes a deviation of maximum 2 cm from the desired track: a degree of accuracy that even the most expert operators cannot achieve. Precision farming allows farmers to maximize their crop productivity and profitability.



# SATELLITE-BASED GUIDANCE: MORE EFFICIENCY, LESS COSTS



The optional satellite-based guidance system is controlled via a dedicated 8.4" touch screen monitor in conjunction with a satellite antenna fitted on the roof of the tractor cab.

The monitor manages two functions:

1. The Precision Steering Management system, which provides precise steering control delivering up to 2cm pass-to-pass accuracy in row-crop operations. Such a high level of precision greatly increases productivity per unit land area.
2. Configuration and control of the ISOBUS system with management of advanced features such as TC-GEO.

## **ELECTRONIC STEERING WHEEL**

The X5 Series tractors can be specified with the Topcon electronic steering wheel which allows extremely precise steering, thereby reducing operator fatigue and saving time and fuel.

## **SATELLITE ANTENNA**

The satellite antenna placed on the cab roof receives the GPS signal.





# ISOBUS SYSTEM FOR SIMPLE AND EFFICIENT IMPLEMENT CONTROL

The X5 tractor range can be optionally equipped with an ISOBUS terminal to increase operating efficiency and productivity. With the ISOBUS system, the operator manages the implements via a simple touch screen monitor, without the need to install a dedicated control unit inside the cab.



## TOUCH SCREEN MONITOR

An 8.4-inch touch screen monitor manages the satellite-based guidance and the ISOBUS system.

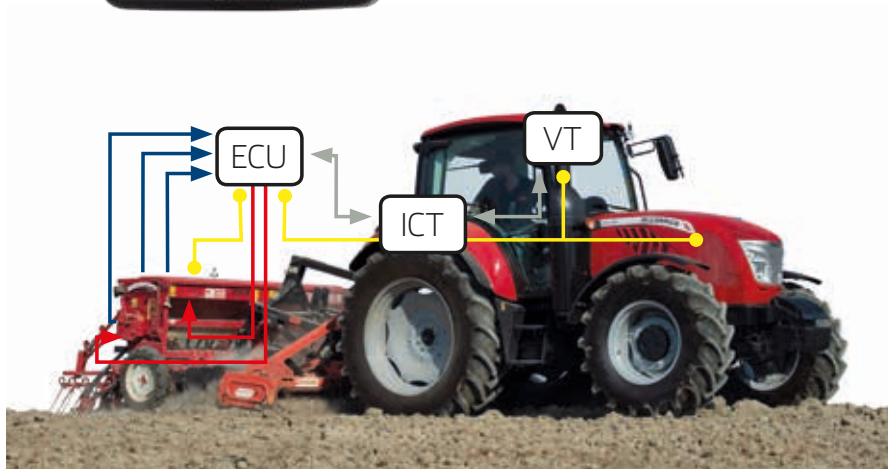

## Benefits of satellite-based guidance and ISOBUS system

The satellite-based guidance and the ISOBUS system maximise efficiency and productivity while improving riding comfort and safety:

- › Each implement operation is controlled with extreme accuracy. Implement can also be managed automatically.
- › Reducing the travelled distance in the field reduces tractor and implement wear and saves fuel.
- › The application of variable rate treatments eliminates skips and overlaps; this minimizes product wastes and reduces working time while maximizing efficiency and crop yield.
- › Precision farming reduces chemical residues. For example, it makes it possible to place fertilizer only in a specific row that will be sown at a later date: at the time of seeding, the row will be found thanks to the map system of the automatic guidance.
- › Report and pre-setting operations become more user-friendly and can be done from home. This eliminates the need for expert operators, thus reducing operating costs.

# QUICK MAINTENANCE TO GET YOU BACK UP AND RUNNING

- › The tilt-up hood opens wide to provide easy access to the engine compartment for maintenance.
- › Oil filler cap is placed in the lower part of the engine, so topping up of engine oil can be done without opening the hood.
- › Engine air filter is positioned in such a way as to facilitate cleaning and replacement.
- › The cooling radiators, mounted in the engine front, and the laterally-removable dust cover allow simple and fast cleaning.
- › The fuel tank is conveniently placed to allow quick filling.
- › In-cab air filter is easily accessible for maintenance.
- › Oil level in the transmission can be conveniently checked through the oil filler cap with dipstick placed on the rear of the tractor.
- › Windscreen wiper fluid reservoir is located on the back of the cab.

Designed to deliver maximum efficiency and reliability, the X5 Series offers a variety of solutions to simplify and expedite maintenance.







## McCORMICK SPARE PARTS AND SERVICE, TO GIVE YOU THE BEST ALWAYS

McCormick is worldwide recognized as a reliable supplier of high-quality spare parts and after-sales services. Developed by the same engineers who design and manufacture the McCormick tractors, genuine McCormick parts are designed and manufactured to the highest quality standards to ensure tractors reliable performance and maximum safety.

The pluses of McCormick's after-sales service include following:

- Spare parts are delivered promptly and efficiently to McCormick's dealers on the same day of order.

- Each part comes with a 12-month warranty and bears a non-falsifiable hologram which certifies its build quality and genuineness.

- Original McCormick parts are reliable and convenient, as they enhance the working quality and efficiency of the **X5** tractors.

After-sales service is handled by our dealers through a team of highly-skilled, solution-oriented technicians who avail themselves of the latest diagnostic techniques. Choosing McCormick means choosing excellence.





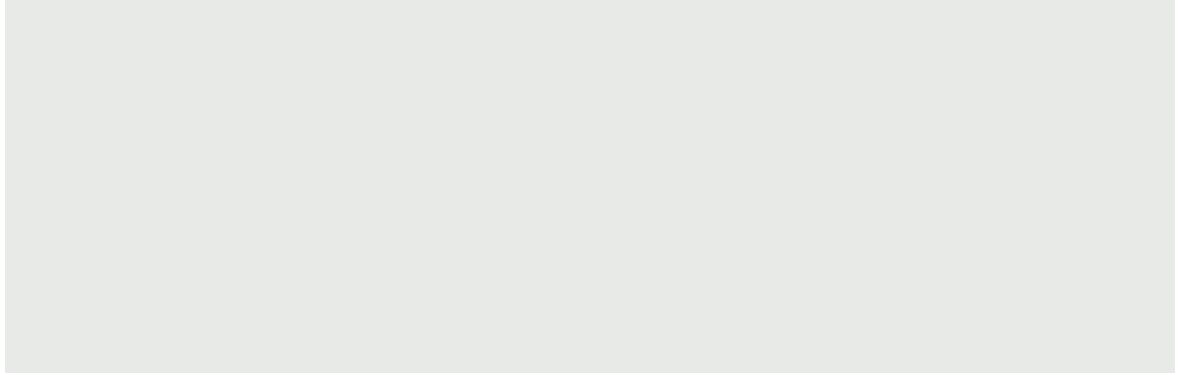

# McCORMICK, INNOVATORS BY TRADITION



Cyrus Hall McCormick was born in Virginia, United States, in 1809. As a pioneer in engineering, McCormick had a stunning ability to mechanize farm work, as he demonstrated when, in 1831, he invented the first mechanical reaper. The McCormick company was established in 1847. It produced wheat harvesters. Starting from 1866, the company adopted the colour red which from then on would distinguish McCormick around the world. In 1871, McCormick manufactured the greatest number of machines than any other company: 250 reapers per day. The first tractor, the Mogul 8-16, was launched in 1910. In those years, the company opened up factories in Canada, Great Britain, Germany, France and Sweden. In the following years, the company was bought and sold various times. In 2001, McCormick was acquired by the Argo Group, which re-launched the brand under the name McCormick Tractors International Limited. Today, McCormick is a world leader in the tractor industry and its name stands for uncompromised technology and innovative design. Thanks to heavy investments in research and development, the new generation of McCormick tractors is now positioned at the top of the market for performance and innovation. Farmers look for performance, reliability and versatility and this is exactly what McCormick offers its customers to maximize their productivity.



# ARGO TRACTORS: QUALITY OF WORK, QUALITY OF LIFE

Picking up and revitalizing the wealth of experience and technology of companies that have made the history of mechanized farming. This is the commitment of Argo Tractors SpA, the industrial group that with the Landini, McCormick and Valpadana brands has created a global tractor manufacturing hub. Argo Tractors' strategy is based on close integration between engineering, manufacturing and marketing activities. The R&D and engineering division is located at the main headquarters in Fabrico (Reggio Emilia). The production is based on the synergy between three plants, each of which dedicated to a specific product line, and two spare parts distribution centres based in Italy and the United States.

Today, with the Landini, McCormick and Valpadana brands, Argo Tractors offers one of the most comprehensive product ranges on the market, covering 3-, 4- and 6-cylinder tractor families in the power range from 25 to over 310 hp for a variety of open-field, vineyard and orchard applications, including crawler, utility and equal-wheeled tractors. But more importantly, at the heart of Argo Tractors' project is man, with the company's commitment to respect the environment and make the daily work of farmers safer and more comfortable.







	X5.35	X5.45	X5.55
<b>ENGINE</b>			
STAGE 3B / TIER 4 INTERIM	DEUTZ - AG	DEUTZ - AG	DEUTZ - AG
MAX POWER ISO	HP/KW 99 / 73	107 / 79	113/83
RATED ENGINE SPEED	RPM 2200	2200	2200
MAX TORQUE	NM 397	420	460
MAX TORQUE SPEED	RPM 1600	1600	1600
BORE / STROKE	MM 98/120	98/120	98/120
DISPLACEMENT / CYLINDERS	CM <sup>3</sup> 3600 / 4 TA	3600 / 4 TA	3600 / 4 TA
DOC AFTER-TREATMENT SYSTEM	●	●	●
FUEL TANK CAPACITY	L 120	120	120
<b>CLUTCH</b>			
INDEPENDENT DRY DUAL CLUTCH	12	12	12
MECHANICALLY-OPERATED	●	●	●
MULTI-DISC WET CLUTCH	○	○	○
DE-CLUTCH CONTROL: BUTTON-OPERATED CLUTCH	○	○	○
<b>TRANSMISSION</b>			
SPEED FOUR + SYNCHRO SHUTTLE: 12FWD + 12REV 40 KM/H	●	●	●
SPEED FOUR + SYNCHRO SHUTTLE + CREEPER: 16FWD + 16REV 40 KM/H	○	○	○
SPEED FOUR + POWER FOUR +SYNCHRO SHUTTLE: 24FWD + 24REV 40 KM/H	○	○	○
SPEED FOUR + POWER FOUR + SYNCHRO SHUTTLE + CREEPER: 32FWD + 32REV 40 KM/H	○	○	○
SPEED FOUR + POWER FOUR + POWER SHUTTLE: 24FWD + 24REV 40 KM/H	○	○	○
SPEED FOUR + POWER FOUR + POWER SHUTTLE + CREEPER: 32FWD + 32REV 40 KM/H	○	○	○
XTRASHIFT + SPEED FOUR + POWER SHUTTLE: 36FWD + 12REV (3-STAGE POWERSHIFT )	○	○	○
XTRASHIFT + SPEED FOUR + POWER SHUTTLE + CREEPER: 48FWD + 16REV	○	○	○
ECO FORTY (40 KM/H AT REDUCED ENGINE RPM)	○	○	○
REVERSE POWER SHUTTLE	○	○	○
SHUTTLE MODULATION CONTROL: ADJUSTMENT OF POWER SHUTTLE RESPONSE	○	○	○
PARK LOCK	○	○	○
<b>POWER TAKE-OFF</b>			
WET MULTI-DISC PTO CLUTCH	●	●	●
ELECTROHYDRAULIC ENGAGEMENT	●	●	●
2 SPEEDS: 540/540E RPM	●	●	●
2 SPEEDS: 540/1000 RPM	○	○	○
4 SPEEDS: 540/540E/1000/1000E RPM	○	○	○
1"3/8 (34.9 MM) PTO SHAFT WITH 6 SPLINES	●	●	●
1"3/8 (34.9 MM) PTO SHAFT WITH 21 SPLINES	○	○	○
GROUND SPEED PTO	○	○	○
<b>FRONT 4WD AXLE</b>			
ELECTROHYDRAULIC 4WD ENGAGEMENT	●	●	●
RIGID TYPE	●	●	●
MAX STEERING ANGLE	55°	55°	55°
TWIN-LOCK ELECTROHYDRAULIC DIFFERENTIAL LOCK	●	●	●
<b>BRAKING SYSTEM</b>			
HYDROSTATICALLY-OPERATED ANNULAR PISTON BRAKES	●	●	●
AUTOMATIC 4WD ENGAGEMENT ON BRAKING	●	●	●

		X5.35	X5.45	X5.55
<b>BRAKING SYSTEM</b>				
WET MULTI-DISK FRONT BRAKES		○	○	○
INTEGRAL BRAKING SYSTEM - IBS		●	●	●
HYDRAULIC TRAILER BRAKING		○	○	○
PNEUMATIC TRAILER BRAKING		○	○	○
<b>HYDRAULIC SYSTEM</b>				
DRAFT, POSITION, MIXED AND FLOAT CONTROL		●	●	●
MECHANICALLY-CONTROLLED REAR HITCH		○	○	○
ERGONOMIC LIFT SYSTEM		○	○	○
ELECTRONICALLY-CONTROLLED REAR HITCH		○	○	○
LIFT CAPACITY WITH 2 ASSISTOR RAMS	KG	4500	4500	4500
MAX WORKING PRESSURE	BAR	180	180	180
PUMP FLOW RATE (HITCH + STEERING)	L/MIN	62+32	62+32	62+32
THREE-POINT HITCH CATEGORY 2		●	●	●
HYDRAULIC ADJUSTMENT OF RIGHT LIFTING ROD AND TOP LINK		○	○	○
REMOTE VALVES STD / OPT		2- 3	2- 3	2- 3
NO. 2 FRONT REMOTES + JOYSTICK		○	○	○
FRONT HITCH AND PTO (MAX LIFT CAPACITY)	KG	2200	2200	2200
<b>CAB AND DRIVING POSITION</b>				
TOTAL VIEW SLIM CAB / RADIO ADAPTOR		●	●	●
HEATING / VENTILATION		●	●	●
AIR-CONDITIONING		○	○	○
AIR SUSPENSION SEAT		○	○	○
DIGITAL INSTRUMENT PANEL		●	●	●
<b>DIMENSIONS ET POIDS</b>				
A - MAX LENGTH 4WD (WITH BALLAST WEIGHTS)	MM	4408	4408	4408
B - MIN WIDTH	MM	1900	1900	1900
C - WHEELBASE	MM	2355	2355	2355
D - HEIGHT OVER CAB	MM	2615	2615	2615
E - GROUND CLEARANCE	MM	350	350	350
WEIGHT IN RUNNING ORDER (WITHOUT BALLAST WEIGHTS)	KG	3800	3800	3800
<b>OPTIONAL EQUIPMENT</b>				
N. 10 FRONT BALLASTS 362 KG EACH		○	○	○
WEIGHT FOR FRONT HITCH 300 KG		○	○	○

Key: ● standard ○ option — not available

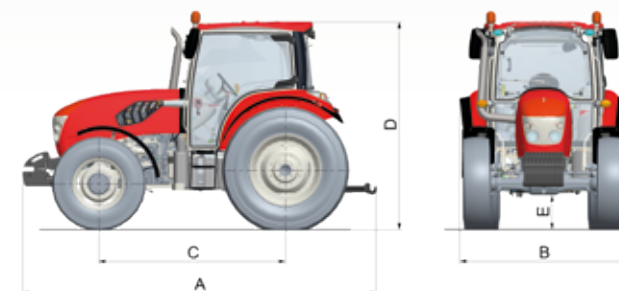



**Power Technology.**

via G. Matteotti, 7 | 42042 Fabbrico [RE] Italia | t. +39.0522.656.111 | f. +39.0522.656.476  
webmaster@argotracors.com | www.argotracors.com



graphic design : **gruppo saldatori** | [www.grupposaldatori.com](http://www.grupposaldatori.com)  
Les données techniques et les illustrations contenues dans  
cette publication sont fournies à titre d'information seulement  
et donc peuvent être modifiées sans préavis.

  
**6636959A1**